

Status: 02/2025

cab
we identify more

NEW
Applicators HQ



Print and
apply systems
for industrial operation

HERMES Q

Made in Germany



Data security in label printing

Modern manufacture sees marking systems work autonomous, interact among each other, with host computers or a plant control unit. Data security is a key issue. The integration of components, their administration and authentication are sensitive tasks demanded from the corporate IT. cab systems developed for printing and applying labels provide proper features by default, fairly protecting your data in a network.



Permissions can be assigned to users and restricted by passwords.



Firmware updates are verified for integrity before installation.



Access to network services (HTTP, FTP, VNC, OPC UA etc.) is possible only for users with authorization. Network services can be switched on or off.



Network protocols can be encrypted using TLS/SSL. To connect securely in a network, a certificate as required is installed in the device ex factory.



WLAN can be switched on or off. WPA2, WPA2 Enterprise and WPA3 levels of security are supported.



Printers in a network can be authorized securely. IEEE 802.1X network standard is supported.



USB slots can be locked and access to external storage media be denied.

All the current cab printing systems are based on the same electronics and firmware. The printer language is the same, so are interfaces and memory. Any further developed operating system or driver is available immediately on every device. Resets to default settings are PIN-protected.



Contents

Page 2	cabPROTECT
Pages 4 - 13	HERMES Q
Pages 14 - 15	Software
Pages 16 - 36	Applicators
Page 37 - 38	Tools for assembly
Pages 39 - 40	Floor stands
Pages 42 - 46	Delivery program
Page 47	cab product overview

HERMES Q

Printing labels and applying them automatically in production lines



The slim one

to print small labels

Label printer		HERMES Q2	
Printable resolution	dpi	300	600
Print speed	up to mm/s	300	150
Print width	up to mm	56.9	54.1
Label roll outside diameters	mm	205 / 305	
Label width	up to mm	58	



The universal one

An industrial bestseller, providing a wide range of accessories

Label printer		HERMES Q4.3		HERMES Q4	
Printable resolution	dpi	200	300	300	600
Print speed	up to mm/s	300	300	300	150
Print width	up to mm	104	108.4	105.7	105.7
Label roll outside diameters	mm	205 / 305			
Label width	up to mm	114			



The wide one

to print Odette, UCC and GS1 labels in logistics applications

Label printer		HERMES Q6.3	
Printable resolution	dpi	200	300
Print speed	up to mm/s	250	250
Print width	up to mm	168	162.6
Label roll outside diameters	mm	205 / 305	
Label width	up to mm	174	

Sample applications



Label rolls

All units can provide an unwinder for picking up rolls with maximum diameter either 205 mm or 305 mm.



Directions to which dispense labels

All units can be designed for providing labels either to the left or to the right.



Orientations of assembly

All the units can be rotated vertically by at most 360° or assembled in horizontal orientation.

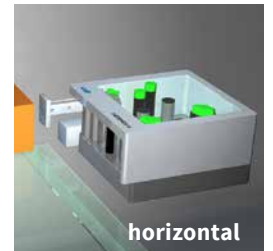
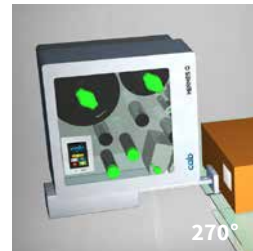
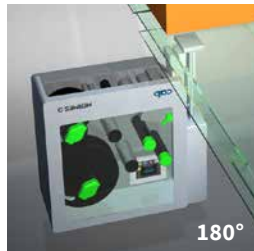
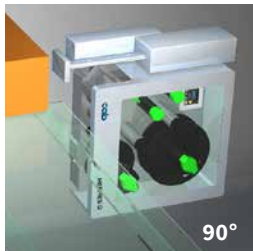
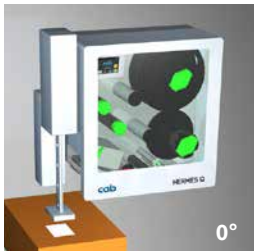

HERMES Q in detail



1 Operation panel

Self-explanatory symbols are on display. The device can thus be operated intuitively and settings be configured easily.

2 Ribbon holder

On the basis of three-part tightening axes, ribbons can be replaced easily and quickly.

3 Rugged metal chassis

It is made of cast aluminum. All the parts are assembled to it.

4 Applicator

It is assembled to hinge pins. It can be pivoted in case of maintenance or if materials have to be replaced.

5 Pressing plungers

One is fixed near the chassis wall. The second one is pushed to the label margin, as far as necessary to evoke a good print image.

6 Print head

Units of the same width are interchangeable. Replacement requires only few steps.

7 Print roller

It can be removed/inserted quickly in cases of cleaning or wear.

8 Peel-off plate

Pivoting improves labels be applied to packages.

9 Label unwinder

A swing arm and an integral brake enable labels be unwound at constant force.

10 Liner rewinder

Subsequent to all the labels been dispensed, the entire liner tape is rewound. On the basis of a three-part tightening axle, a liner tape can be inserted and removed easily.

11 Pulling system

A liner tape is clamped between a draw roller and a pinch roller. Labels are dispensed using feed synchronous to the print roller.

12 Label sensor

Imprint is precisely set on spot on a label and materials ending detected by a transmissive or a reflective sensor.

Accurate imprint

The smaller a label, the higher are the demands regarding the accuracy of an imprint. Print offset can be reduced by ± 0.2 mm using adjustable slip correction.

Print heads



Units of the same width are interchangeable. They are detected by the CPU automatically and calibrated. The print distance to the locating edge can be adjusted.

Major data such as the operational performance, maximum operating temperature and heat energy are recorded on the print head. Data can be read at the factory.

Print heads provided for HERMES Q2, HERMES Q4 - 300, 600 dpi

- sharp-edge print images
- e.g. when printing small fonts and graphics on typeplates
- e.g. when printing on materials requires high energy needs

Print heads provided for HERMES Q4.3, HERMES Q6.3 - 200, 300 dpi
persistent; when labeling in rough settings and thermal direct method

Print rollers



Two types of materials:

Print rollers DR

providing a synthetic rubber coating
They enable highly accurate imprint and are provided by default.

Print rollers DRS

providing a silicone coating
Product life is extra long, taken a higher print offset into account.

Interfaces



- 1 Slot to insert a **SD memory card**
- 2 **2 USB hosts** to connect a service key, USB memory stick, keyboard, barcode scanner, USB WLAN stick, warning light, an external operation panel
- 3 **USB 2.0 Hi-Speed** to connect a PC
- 4 **Ethernet 10/100 Mbit/s**
- 5 **RS232C** 1,200 to 230,400 baud /8 bits
- 6 **Digital I/O interface;** socket connector SUB-D, 25 pins compliant with IEC/EN 61131-2, types 1+3;
All the inputs and outputs are isolated galvanically and protect from reverse polarity. In addition, outputs are short-circuit proof

PNP inputs

Start printing or labeling
Print first label
Reprint
Delete print job
Label removed
Stop printing or labeling
Label feed
Label rotated by 90°
(to be applied by applicator 4214)
Pause
Reset

PNP, NPN outputs

Device ready
Print data available
Initial / upper end position
Paper feed ON
Label in transfer position
Label application / lower end position
Pre-warning to a ribbon ending
Pre-warning to a label web ending
End of a ribbon and/or a label web
Collective error

Option:

- 7 **2 port Ethernet switch 10/100 Mbit/s**

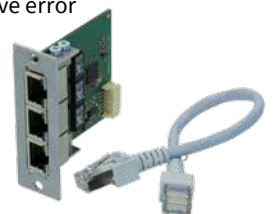







Operation panel

Self-explanatory symbols are on display. The device can thus be operated intuitively and settings be configured easily.

- 1 **LED:** Power ON
- 2 **Status bar:** data reception, record data stream, pre-warning to a ribbon ending, SD memory card / USB memory stick plugged in, WLAN, Ethernet, USB slave, time
- 3 **Printer status:** ready, pause, number of labels printed in a print job, label in transfer position, awaiting external start signal
- 4 **USB slot** to connect a service key or a memory stick, to transfer data to the IFFS memory

5 Operation

-  Printing and applying labels in individual steps
-  Jump to menu
-  Reprint the latest label
-  Interrupt and continue a print job
-  Stop and delete all print jobs
-  Label feed



Setup options



Print parameters

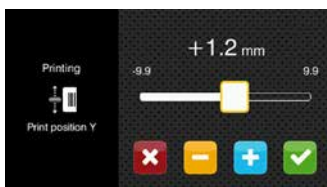

Print offset Y

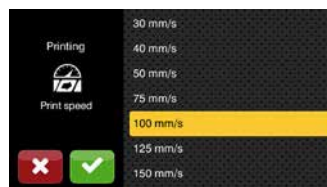

Print speeds

Landscape or portrait display, depending from the orientation of assembly



Printer rotated by 90°



Video tutorials

External operation panel

If the operation panel of a printer cannot be accessed, an additional external one can be plugged.

Same functionality as on the printer

Landscape or portrait mode

Operability as desired on the external operation panel or on the printer

Printer connectivity: USB 2.0 Hi-Speed device

- 1 **LED:** Power ON
- 2 **USB port** to plug a service key or a memory stick, to transfer data to the IFFS memory
- 3 **Connecting USB cable** for power supply
cab provides specified cables. Lengths are 1.8 m to 16 m.









Accessories

Accessorial products are plugged or screwed to a printer by the customer.

Pos.	Designation	roll Ø	205	305	1.1	1.2		1.3
					HERMES Q2	HERMES Q4.3	HERMES Q4	HERMES Q6.3
2.1	SD memory card		●	●	<input type="checkbox"/>	<input type="checkbox"/>	<input type="checkbox"/>	<input type="checkbox"/>
2.2	USB memory stick		●	●	<input type="checkbox"/>	<input type="checkbox"/>	<input type="checkbox"/>	<input type="checkbox"/>
2.3	USB WLAN stick		●	●	<input type="checkbox"/>	<input type="checkbox"/>	<input type="checkbox"/>	<input type="checkbox"/>
2.4	USB WLAN stick including a rod antenna		●	●	<input type="checkbox"/>	<input type="checkbox"/>	<input type="checkbox"/>	<input type="checkbox"/>
2.6	Product sensor, 3 pins		●	●	-	<input type="checkbox"/>	<input type="checkbox"/>	<input type="checkbox"/>
2.7	Product sensor, 25 pins		●	●	<input type="checkbox"/>	<input type="checkbox"/>	<input type="checkbox"/>	<input type="checkbox"/>
2.8	I/O interface connector SUB-D, 25 pins		●	●	<input type="checkbox"/>	<input type="checkbox"/>	<input type="checkbox"/>	<input type="checkbox"/>
2.9	Warning light		●	●	<input type="checkbox"/>	<input type="checkbox"/>	<input type="checkbox"/>	<input type="checkbox"/>
2.10	External operation panel		●	●	<input type="checkbox"/>	<input type="checkbox"/>	<input type="checkbox"/>	<input type="checkbox"/>
	Connecting USB cable		●	●	<input type="checkbox"/>	<input type="checkbox"/>	<input type="checkbox"/>	<input type="checkbox"/>
2.11	Label selection - I/O box		●	●	<input type="checkbox"/>	<input type="checkbox"/>	<input type="checkbox"/>	<input type="checkbox"/>
2.12	Hand switch TR2		●	●	<input type="checkbox"/>	<input type="checkbox"/>	<input type="checkbox"/>	<input type="checkbox"/>
2.13	Foot switch		●	●	<input type="checkbox"/>	<input type="checkbox"/>	<input type="checkbox"/>	<input type="checkbox"/>
2.14	Connecting RS232 C cable		●	●	<input type="checkbox"/>	<input type="checkbox"/>	<input type="checkbox"/>	<input type="checkbox"/>
2.15	Scanner CC200		●	●	<input type="checkbox"/>	<input type="checkbox"/>	<input type="checkbox"/>	<input type="checkbox"/>

2.1		SD memory card
2.2		USB memory stick
2.3		USB WLAN stick 2.4 GHz 802.11b/g/n hotspot or infrastructure mode
2.4		USB WLAN stick including a rod antenna to extend the range of operation 2.4 GHz 802.11b/g/n + 5 GHz 802.11a/n/ac hotspot or infrastructure mode
2.6		Product sensor, 3 pins to be attached to a front side applicator, a vacuum belt applicator or an air jet box. Labels are triggered to be applied as soon as a product has been detached, e.g. on a conveyor belt.
2.7		Product sensor, 25 pins Labels are triggered to be applied as soon as a product has been detached, e.g. on a conveyor belt.
2.8		I/O interface connector SUB-D, 25 pins All control signals can be attached to the I/O interface using clamping screws.
2.9		Warning light In addition to the information indicated on the display of a printer, states are signalled. Red Collective error Yellow Pre-warning to a label web or a ribbon ending Green Device ready USB cable (1 m) to connect to HERMES Q Assembly materials are provided for vertical printer installation only. 1 Chassis assembly 2 Bracket assembly

2.10		External operation panel If the operation panel of a printer cannot be accessed, an additional external one can be plugged. Same functionality as on the printer Landscape or portrait mode Operability as desired on the external operation panel or on the printer
		Printer connectivity: USB 2.0 Hi-Speed device cab provides specified connecting USB cables for power supply. Lengths are 1.8 m to 16 m.
2.11		Label selection - I/O box A maximum of 16 different labels can be selected from a memory card by a master control unit, e.g. PLC.
2.12		Hand switch TR2 to be attached to the I/O interface
2.13		Foot switch to be attached to the I/O interface
2.14		Connecting RS232 C cable 9/9 pins, 3 m
2.15		Scanner CC200 provided on request

Options are parts or units to perform special functions. They are assembled to a printer in addition to or instead of standards.

If order implies options be assembled ex factory, the part numbers of such printers and options are added by .250. Options delivered separately are added by .001.

Pos.	Designation	roll Ø	205	305	HERMES Q2	HERMES Q4.3	HERMES Q4	HERMES Q6.3	.250	.001
3.1	Automatic ribbon saving		●	●	-	□	□	□	●	-
3.2	UHF RFID module		●	●	-	□	□	□	●	-
3.3	Label unwinder K40		●	●	□	□	□	□	●	●
3.4/3.5	Adapters 40/50 and 76/100		●	●	□	□	□	□	●	●
3.6	Spacers		●	-	□	□	□	-	●	●
3.7	Margin stop 10		●	-	□	□	□	□	●	●
3.8	Cover		●	-	□	□	□	□	●	●
3.9	Print head pressure system, reduced force		●	●	□	□	-	□	●	●
3.10	Extended peel-off plate (+10 mm)		●	●	□	□	□	□	●	●
3.11	Print roller DRS		●	●	□	□	□	□	●	●
3.12	Antistatic brush		●	●	□	□	□	-	●	●
3.13	Draw roller ZS		●	●	□	□	□	□	●	●
3.14	Interface for plugging an external label sensor		●	●	□	□	□	□	●	●
3.15	2 port Ethernet switch 10/100 Mbit/s		●	●	□	□	□	□	●	●
3.16	Label sensor, modified		●	●	□	-	-	-	●	●



3.1

assembly
ex factory only

Automatic ribbon saving

Use is recommended in cases of at least 60 mm unprinted area on a label. While labels are fed, the print head is lifted and the ribbon stopped, resulting in less material consumption.



3.2

assembly to
a printer ex factory
excludes automatic
ribbon saving

UHF RFID module

Read/write antennas are assembled directly to a print head or a feeding unit. Using a 4214 applicator enables defective labels be ejected.



See information on www.cab.de/en/rfid



3.3



3.4

Adapter 40/50

to pick up label rolls having a core diameter of 50 mm and minimum widths of 20 mm. One adapter is sufficient if material width does not exceed 50 mm.



3.5



Adapter 76/100

to pick up label rolls having a core diameter of 100 mm and minimum widths of 20 mm. One adapter is sufficient if material width does not exceed 50 mm.



3.7



3.16

Spacers

to process narrow labels provided on liners ≤ 20 mm wide, wound on a roll or a reel.

Ribbon protruding on both sides prevents from wrinkling. The label guidance is therefore offset by 7 mm from the middle wall with spacers.

A modified label sensor is included on delivery.

Reel plate wall thickness 1 - 2 mm

Label sensor, modified

Provided for labels requiring a sensor distant up to 26 mm to the locating edge. This sensor cannot be fixed with a screw.



3.7



Margin stop 10

to guide narrow labels provided on a liner 10 - 24 mm wide, wound on a roll (no reels) having a core diameter of 76 mm.

Operate only with a spacer

Options

3.8

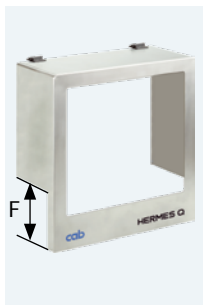

Cover

to prevent from contamination and contact
 Maximum outside diameter for label rolls is 205 mm
 Assembly in vertical orientation, rotated by $\pm 90^\circ$ or horizontally
 Depth of a pad immersing Dim. F

	Dimension F mm		
	Standard	Optional	on request
HERMES Q2	60	100	up to 120
HERMES Q4/Q4.3	60	100	up to 120
HERMES Q6	25	-	up to 120

3.9



Print head pressure system, reduced force

Thermal direct printing requires less pressure on a print head.
 Reduced force results in a decrease of wear. Product life extends.

Thermal direct printing only

3.10



Extended peel-off plate (+10 mm)

Recommended

- if labels are picked up by a robotic arm,
- if readable area is required for scanning,
- when installing an antistatic brush

3.11



Print roller DRS

Silicone coating enables an extra long product life,
 taken a higher print offset into account

3.12



Antistatic brush

Electrostatic charge is reduced when plastic labels
 are printed and peeled off.

Operate only with an extended peel-off plate.

3.13



Draw roller ZS

Made of steel, to avoid tension on a liner tape:

- if label height exceeds 150 mm
- when peeling off without backfeed
- if thick liner materials are processed
- when applying labels using a demand module 5114/16

3.14



Interface for plugging an external label sensor

M12 plug, 5 pins, a-coded
 Plug-compatible with CEON and other sensors based on
 PNP and 24 V

3.15



2 port Ethernet switch 10/100 Mbit/s

to connect another terminal device in a joint network.
 Signals are looped through.

Technical data

● typical ■ standard □ option

Label printer		type	HERMES Q2		HERMES Q4.3		HERMES Q4		HERMES Q6.3	
Printing method	Thermal transfer		●	●	●	●	●	●	●	●
	Thermal direct		-	-	●	●	-	-	●	●
Printable resolution	dpi		300	600	200	300	300	600	200	300
Print speed	up to mm/s		300	150	300	300	300	150	250	250
Print width	bis mm		56.9	54.1	104	108.4	105.7	105.7	168	162.6
Direction to which dispense labels			L = to the left, R = to the right							
Print distance to the locating edge	mm		1	1	1	1	1	1	1	1
incl. automatic ribbon saving L/R mm			-	-	2.2/1.6	0/-0.7	1/1	1/1	0.2/0.2	2.9/2.9
UHF RFID										
UHF RFID module			-	-	□	□	□	□	□	□
Materials										
Labels			paper, PET, PE, PP, PI, PVC, PU, acrylate, Tyvec							
		on a roll	●		●		●		●	
		on a reel	●		-		-		-	
Labels ¹⁾	Width	mm	4 - 58		10 - 114		10 - 114		46 - 174	
	Height	from mm	3		4		4		6	
	Thickness	up to mm	0.60		0.60		0.60		0.60	
Liner tape	Width if operating a roll	mm	24 - 62		24 - 118		24 - 118		50 - 178	
	Width ²⁾ if operating a reel or a roll	mm	10 - 24		-		10 - 24		-	
	Thickness	mm	0.03 - 0.08		0.03 - 0.08		0.03 - 0.08		0.03 - 0.08	
Roll unwinder	Outside roll diameter	up to mm	205 / 305		205 / 305		205 / 305		205 / 305	
	reel diameter	up to mm	205		-		-		-	
	Core diameter	mm	76							
	Winding		outside or inside							
Roll rewinder	Outside diameter	up to mm	155 / 205							
	Core diameter	mm	76							
Ribbon ³⁾	Ink side		outside or inside							
	Roll diameter	up to mm	90							
	Core diameter	mm	25.4							
	Length	up to m	600							
	Width	mm	25 - 67		25 - 114		25 - 114		50 - 170	
	Automatic ribbon saving		-		□		□		□	
Printer dimensions and weights										
Width	mm		207		260		260		320	
Height	roll diameters 205 / 305	mm	400 / 430							
Depth	roll diameters 205 / 305	mm	400 / 500							
Weight kg	roll diameters 205 / 305	approx..	15 / 16		16 / 17		16 / 17		20	
Label sensor indicating positions										
Transmissive sensor		detecting	labels, punch marks or print marks, as well as materials ending							
Reflective sensor		bottom reflex	detecting print marks on non-transparent liners, as well as materials ending							
Sensor distance to the locating edge		standard	2 - 12		2 - 60		2 - 60		2 - 60	
		modified	2 - 26							
Material passage		mm	2							
Electronics										
32-bit processor		MHz	800							
RAM		MB	256							
IFFS memory		MB	50							
Slot to insert a memory card (SDHC, SDXC)			■							
Battery to display date and real time			■							
Data (e.g. serial numbering) preserved if power turns off			■							
Interfaces										
RS232C 1,200 to 230,400 baud / 8 bits			■							
USB 2.0 Hi-Speed to connect a PC			■							
Ethernet 10/100 Mbit/s			LPD, RawIP printing, SOAP web service, OPC UA, WebDAV DHCP, HTTP/HTTPS, FTP/FTPS, TIME, NTP, Zeroconf, SNMP, SMTP, VNC							
2 USB hosts on the control panel, 2 USB hosts on the back of a unit			Service key, USB stick, USB WLAN stick, USB WLAN stick including a rod antenna, keyboard, barcode scanner, warning light, external control panel							
USB host 24 VDC, to connect a peripheral device			■							
Digital I/O interface, 10 inputs / 11 outputs			■							
Interface for plugging an external label sensor			□							
2 port Ethernet switch 10/100 Mbit/s			□							

¹⁾ Limitations can occur when processing small labels, thin materials or materials using a strong adhesive. Critical applications need testing.

²⁾ Spacers attached to the label unwinder and the unit rewinding the liner tape help feeding the ribbon centered above the labels.

³⁾ The ribbon must correspond at least to the width of the liner tape.

Technical data

■ standard □ option

Operating data	
Voltage	100-240 VAC, 50/60 Hz, PFC
Power consumption	standby <10 W / typical 100 W / max. 200 W
Temperature / Operation	+5 - 40°C / 10 - 85 %, not condensing
humidity	Stock 0 - 60°C / 20 - 85 %, not condensing
	Transport -25 - 60°C / 20 - 85 %, not condensing
Approvals	CE, FCC Class A, ICES-3, cULus, CB, RCM Mark, CCC, CoC Mexico, BSMI Mark, KC Mark
Operation panel	
Colored LCD touch display	Screen diagonal " 4,3 Resolution Width x Height px 480 x 272
Setup options	
Print Labels Ribbon Peel off Apply label Interfaces Error	Region: - Language - Country - Keyboard - Time zone Time Display: - Brightness - Power saving mode - Orientation Interpreter
Status bar	
	Data reception WLAN Record data stream Ethernet Pre-warning to a ribbon ending USB slave SD memory card plugged in Time USB memory stick plugged in
Monitoring	
	Ribbon Direction of winding Pinch roller open Pre-warning Peripheral error Material ending Labels Pre-warning Material ending Print head Voltage Temperature open
Test routines	
System diagnostics	on start-up, the print head is also detected
Information display, print test, analysis	Status printout Test grid List of fonts Label profile List of devices List of events WLAN status Monitor mode Record print data on a memory card
Status reports	- Printout of device settings, e.g. durations of printing and hours in operation - Device status request triggered by software command - Display of network errors, missing links, barcode errors, peripheral errors, etc.
Fonts	
Provided internally	5 bitmap fonts: 7 vector fonts: 12 x 12 dots AR Heiti Medium GB-Mono 16 x 16 dots CG Triumvirate Condensed Bold 16 x 32 dots Garuda OCR-A HanWangHeiLight OCR-B Monospace 821 Swiss 721 Regular, Bold
To be stored	TrueType fonts
Character sets	Windows-1250 to -1257 DOS 437, 737, 775, 850, 852, 857, 862, 864, 866, 869 EBCDIC 500 ISO 8859-1 to -10 and -13 to -16 WinOEM 720 UTF-8 MacRoman DEC MCS KOI8-R Western European Cyrillic Eastern European Greek Chinese, simplified Latin Chinese, traditional Hebrew Thai Arabic

Fonts	
Bitmap fonts	Widths and heights 1 - 3 mm Zoom factors 2 to 10 Orientations 0°, 90°, 180°, 270°
Vector / TrueType fonts	Widths and heights 0,9 - 128 mm Continuous zoom 360° orientation in steps of 1°
Font styles	bold, italic, underlined, outline, inverse - depending from the font type
Character spacing	variable or monospace for fixed spacing
Graphics	
Elements	lines, arrows, rectangles, circles, ellipses - filled or filled with fading
Formats	PCX, IMG, BMP, TIF, MAC, GIF, PNG
Codes	
1D barcodes (linear)	Code 39, Code 93 Interleaved 2/5 Code 39 Full ASCII Ident and routing code Code 128 A, B, C of Deutsche Post EAN 8, 13 Codabar EAN/UCC 128/GS1-128 JAN 8, 13 EAN/UPC Appendix 2 MSI EAN/UPC Appendix 5 Plessey FIM Postnet HIBC RSS 14 UPC A, E, E0
2D and stacked codes	DataMatrix DataMatrix Rectangle Extension QR code Micro QR code GS1 QR code GS1 DataMatrix PDF 417 Micro PDF 417 UPS MaxiCode GS1 DataBar Aztec Codablock F Dotcode RSS 14 truncated, limited, stacked, stacked omni-directional Heights, modular widths and ratio are variable Orientations 0°, 90°, 180°, 270° Check digit, plain text printout and start/stop coding are options depending from the code type.
Software	
Label software	cablabel S3 Lite ■ cablabel S3 Viewer ■ cablabel S3 Pro □ cablabel S3 Print □
Running also with	CODESOFT Loftware Spectrum NiceLabel BarTender
Stand-alone operation	■
Windows printer drivers certified WHQL for	Windows 10 Server 2016 Windows 11 Server 2019 Server 2022 ■
Apple printer drivers	Mac OS X 10.6 or any later release ■
Linux printer drivers	CUPS 1.2 or any later release ■
Programming	JScript printer language ■ abc Basic Compiler ■ ZPL II (Datastream be tested in advance) □
Integration	SAP ■ Database Connector ■
Administration	Printer control ■ Configuration on the Intranet / Internet ■

cab uses free and Open Source software in its products. For information see www.cab.de/opensource

cablabel S3 software

Design, print, administrate

cablabel S3 opens up the full potential of cab devices. Creating a label is the first step. cablabel S3 adapts to requirements easily using a modular design. Plug-ins like the JScript Viewer support native JScript programming, as well as other features. The designer user interface and the JScript code synchronize in real time. The Database Connector and other special features can be integrated, so are barcode verifiers.

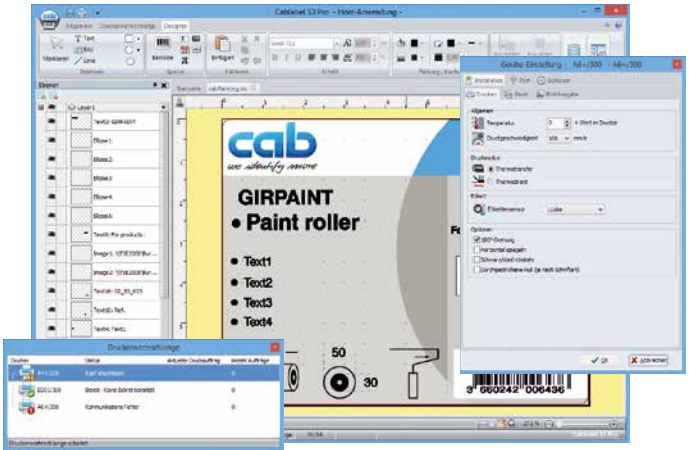

For further information see
www.cab.de/en/cablabel

Stand-alone printing

A printer can select and print labels even when the system is disconnected from a host.

Labels are designed using software such as cablabel S3 or a text editor on a PC. Label formats, texts, graphics and data taken from a database are transferred to a memory card, a USB memory stick or the internal IFFS memory.

Only variable data are sent to the printer using a keyboard, a barcode scanner, scale or another host system and/or are recalled from a host by the Database Connector and printed.



OPC UA

The latest cab printers are ready to interact with machines and components of different manufacturers in industrial plants.

An OPC UA server and a client are part of the firmware.

The server enables a printer be configured and controlled. Dynamic print data can be edited using a defined programming interface.

The integral client enables reading data fields from other machines ready for OPC UA, as well as transferring data to a label. No additional software is needed.



Printer control

Drivers



cab provides drivers to control a printer with software other than cablabel S3.



Free download on www.cab.de/en/support



Programming



JScript

cab printers embed JScript language. Download free manual on www.cab.de/en/programming



abc Basic Compiler

Integral to the firmware, abc in addition to JScript enables advanced programming before data are edited for printout. For example, external printer languages can be replaced without intervening in a print job in progress. Data may be imported as well from other systems such as scales, barcode scanners or PLC.

Connecting to SAP®

Labels can be printed from SAP¹⁾ on cab devices and systems. There are various methods:

- Printing with SAPscript
- Printing with SmartForms
- Printing with Adobe Interactive Forms

See instructions in detail on www.cab.de/en/sap

¹⁾ SAP and associated logos are trademarks or registered trademarks of SAP SE.

Printer administration



Configuration on the Intranet / Internet

Integral HTTP / FTP servers enable a printer be controlled or configured, firmware be updated and memory cards be administrated using standard applications such as a web browser or a FTP client.

Administrators and operators on behalf of SNMP / SMTP are notified of states, alerts and errors by email or SNMP datagrams. Time and date are synchronized by a time server.

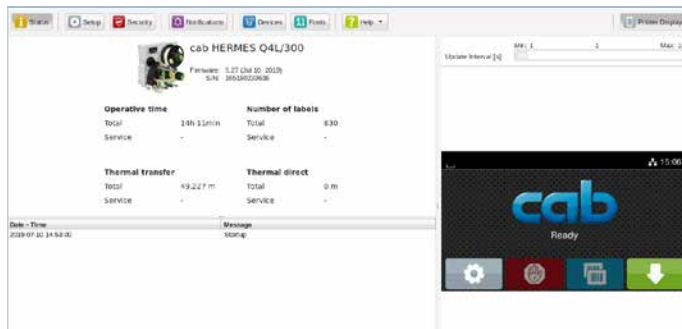

Database Connector

Printers in a network may access data from a ODBC / OLEDB database and print it on labels. Data can be rewritten to a database while print jobs are in progress.



Applicators



Automatic labeling

The HERMES HQ applicators are a further development of the proven HERMES applicators, fully compatible, adding extra functions. Existing applications can continue without limitations.

Easy to configure

The applicator can be fully set on the printer control panel, configurations be stored and called up. Automatic calibration features speed up the setup.

Process control

Detailed statistical values are provided, so are sophisticated error messages. Constant control enables response right away in events of errors.

Updates

Applicator firmware can be updated on the printer control panel or the printer's web server. New features and specific solutions can therefore be tested right away and distributed in the field.

1 Long product life

by a precise and low-wear linear guide

2 Products of variable heights

Labels can be applied on different heights using a stroke cylinder. Its standard lengths are 200, 300 and 400 mm. Further lengths can be provided on request.

3 Protective chassis

is a standard to protect the cylinder and the guide. It can be provided adapted to the product jig on a labeling workstation.

4 Highly reliable processes

Support air and intake air can be defined, so can stroke speed. Sensor control

5 Label application

in real time. Small or large labels, 4 to 250 mm high and 4 to 174 mm wide, can be processed using an applicator

6 Pivoting applicator

The print mechanics can be accessed quickly and easily in case of maintenance or if materials have to be replaced.



Options:

Pressure-reducing valve

It reduces the pressure exerted by the stroke cylinder to a product.

Pressure-reduced applicator

It has been designed for manual workstations missing a protective cover. The cylinder diameter is reduced to 12 mm. To prevent from injuries, a safety valve limits compressed air to a maximum of 4.8 bar.

Applicators, transfer modules and options

Overview

		HERMES Q			Vacuum pad, spring-mounted	Universal pad	Tamp-on pad	Tamp-on pad, providing a damping layer	Tamp-on pad, providing a label stop	Blow-on pad	Form pad	Universal pad, spring-mounted	Tamp-on pad, spring-mounted	Roll-on pad	Corner-wrap pad	Brush	Transportation belt	Vacuum pad	Pressure-reducing valve	Pressure-reduced applicator			
Applicators	Page	2	4	6.3	Transfer modules														Options				
		Order code			10	11	11	12	61	21	88	31	31	41	51			90	.212	.220			
Product marking	Swing applicator	18	HQ 3214	HQ 3214			<input type="checkbox"/>	<input type="checkbox"/>	<input type="checkbox"/>	<input type="checkbox"/>													
	Stroke applicator	19/20	HQ 4114	HQ 4114			<input type="checkbox"/>	<input type="checkbox"/>	<input type="checkbox"/>	<input type="checkbox"/>	<input type="checkbox"/>									<input type="checkbox"/>	<input type="checkbox"/>		
		19/20			HQ 4116			<input type="checkbox"/>	<input type="checkbox"/>	<input type="checkbox"/>	<input type="checkbox"/>										<input type="checkbox"/>		
	Stroke turn applicator	21	HQ 4214	HQ 4214			<input type="checkbox"/>	<input type="checkbox"/>	<input type="checkbox"/>	<input type="checkbox"/>											<input type="checkbox"/>	<input type="checkbox"/>	
	Stroke applicator	22	HQ 4414	HQ 4414			<input type="checkbox"/>	<input type="checkbox"/>	<input type="checkbox"/>												<input type="checkbox"/>	<input type="checkbox"/>	
	Swing stroke applicator	23	HQ 4514	HQ 4514						<input type="checkbox"/>													
Package marking	Front side applicator	25	HQ 3014				<input type="checkbox"/>			<input type="checkbox"/>			<input type="checkbox"/>										
		25		HQ 3016				<input type="checkbox"/>					<input type="checkbox"/>										
	Stroke applicator	26/27	HQ 4014			<input type="checkbox"/>	<input type="checkbox"/>			<input type="checkbox"/>		<input type="checkbox"/>	<input type="checkbox"/>	<input type="checkbox"/>	<input type="checkbox"/>						<input type="checkbox"/>	<input type="checkbox"/>	
		26/27		HQ 4016			<input type="checkbox"/>					<input type="checkbox"/>	<input type="checkbox"/>								<input type="checkbox"/>		
	Stroke applicator	28	HQ 4024		<input type="checkbox"/>																	<input type="checkbox"/>	
	Stroke blow applicator	29	HQ 4614						<input type="checkbox"/>														
	Demand module	30	HQ 5112	HQ 5114	HQ 5116											<input type="checkbox"/>							
	Vacuum belt applicator	31	HQ 5314	HQ 5316																		<input type="checkbox"/>	
		32	HQ 5414	HQ 5416																		<input type="checkbox"/>	
	Demand table	33	HQ 5714																			<input type="checkbox"/>	
Air jet box	34	HQ 6114																			<input type="checkbox"/>		

Applicator type code index HQ 4414L-200

Type	HERMES Q	Code
Label printer	HERMES Q2	2
	HERMES Q4	4
	HERMES Q4.3	4
	HERMES Q6.3	6
Direction to which dispense labels	left	L
	right	R
Cylinder stroke		200
		300
		400
		500
		600
		700
		800

auf Anfrage

Transfer module type code index 4014R-1100

Applicator (see applicator type codes)	Code
Type Vacuum pad, spring-mounted	10
Universal / tamp-on pad, providing sliding foil	11
Tamp-on pad, providing a damping layer	12
Tamp-on pad, providing a label stop	61
Blow-on pad	21
Form pad	88
Universal / tamp-on pad, spring-mounted	31
Roll-on pad	41
Corner-wrap pad	51
Vacuum pad	90
<input type="checkbox"/> Depth of a pad immersing in mm	00

A pad dips into a surface in the range of a label. See specified depths of immersion in the technical data of an applicator.

Swing applicator HQ 3214

Labels very small or midsized can be applied in real time, preferably from the side.

The pad locates in front of the peel-off plate. It picks up a label while it is being printed. A rotary cylinder pivots into position. The label is transferred to a product by a stroke cylinder. Rotary angles and linear hubs are adjustable.



Accessories

5.13 **Blow tube**

5.14 **Unit to regulate compressed air**

4.1



Swing applicator		HQ 3214 L/R-40
Label application		from the side
State of a product	at rest	■
at the moment a label is applied	in motion	only blow-on pad
Product heights	uniform	■
Distance of a product to the peel-off plate	mm	250-280
Linear guidance, horizontal	mm	5-30
Pivot angles		45° - 95°
Weight of applicator	packaging excluded kg	4.5
Consumption of power	W max.	15
Compressed air	bar	4.5
Cycle rate ¹⁾	labels/min approx.	20

¹⁾calculated using labels 40 mm high and a print speed of 100 mm/s



Tamp-on pad

Labels are precisely tamped on plane surfaces. Recessed levels are possible as well.



Tamp-on pad, providing a damping layer

When applying labels to hard surfaces, the noise level is reduced. It benefits also in cases of rough structures or little unevenness.

Tamp-on pad, providing a label stop

It enables small labels be applied exactly on spot to a product.



Blow-on pad

It benefits when labels have to be applied to sensitive surfaces or products in motion. Labels are blown on by a blast of air. Stroke cylinder adjustment enables bridging distances of 5 to 10 mm to the surface of a product.

			Tamp-on pad	Tamp-on pad, providing a damping layer	Tamp-on pad, providing a label stop	Blow-on pad
Transfer modules			3214 L/R 11 F	3214 L/R 12 F	3214 L/R 61 F	3214 L/R 2100
Label widths	HERMES Q2	mm	4-58	10-58	10-58	10-58
	HERMES Q4/Q4.3	mm	10-114	10-114	10-114	10-80
Label heights	HERMES Q2	mm	5-80	8-80	5-80	10-80
	HERMES Q4/Q4.3	mm	8-80	8-80	8-80	10-80
Depth of a pad immersing F		up to mm	30	30	30	-

Stroke applicators HQ 4114, HQ 4116

Labels very small or midsized can be applied in real time from all sides.

The pad locates in front of the peel-off plate. It picks up a label while it is being printed. Powered by a short stroke cylinder, the pad is brought into position in horizontal direction. The label is transferred to a product by a stroke cylinder. The length of the stroke cylinder defines the maximum distance of a product to the peel-off plate.



Accessories

- 5.13 **Blow tube**
- 5.14 **Unit to regulate compressed air**

Options

- 5.17 **Pressure-reducing valve**
- 5.18 **Pressure-reduced applicator**



Stroke applicators	HQ 4114 L/R-200	HQ 4114 L/R-300	HQ 4114 L/R-400	HQ 4114 L/R-600	HQ 4116 L/R-200	HQ 4116 L/R-300	HQ 4116 L/R-400	
Label applications	from the top, from below, from the side							
State of a product at rest	■							
at the moment a label is applied	in motion							
Product heights	uniform							
	variable							
Short stroke cylinder, horizontal	mm							
	10							
Distance of a product to the bottom of the unit	up to mm	135	235	335	535	135	235	335
Weight of applicator	packaging excluded kg	5	6	7	9	5	6	7,5
Consumption of power	W max.				15			
Compressed air	bar				4.5			
Cycle rate ¹⁾	labels/min approx.				30			

¹⁾ Calculated using a stroke of 100 mm below the unit, labels 40 mm high, a print speed of 100 mm/s



Tamp-on pad

Labels are precisely tamped on plane surfaces. Recessed levels are possible as well.



Tamp-on pad, providing a damping layer

When applying labels to hard surfaces, the noise level is reduced. It benefits also in cases of rough structures or little unevenness.

Tamp-on pad, providing a label stop

It enables small labels be applied exactly on spot to a product.



Blow-on pad

It benefits when labels have to be applied to sensitive surfaces or products in motion. Labels are blown on by a blast of air. Stroke cylinder adjustment enables bridging distances of 5 to 10 mm to the surface of a product.

			Tamp-on pad	Tamp-on pad, providing a damping layer	Tamp-on pad, providing a label stop	Blow-on pad
Transfer modules			4114, 4116 L/R 11 F	4114, 4116 L/R 12 F	4114, 4116 L/R 61 F	4114 L/R 2100
Label widths	HERMES Q2	mm	4-58	10-58	10-58	10-58
	HERMES Q4/Q4.3	mm	10-114	10-114	10-114	10-114
	HERMES Q6.3	mm	50-174	50-174	50-174	-
Label heights	HERMES Q2	mm	4-80	8-80	4-80	10-80
	HERMES Q4/Q4.3	mm	8-80	8-80	8-80	10-80
	HERMES Q6.3	mm	8-80	8-80	8-80	-
Depth of a pad immersing ^{F2)}	up to mm	130	130	130	-	

²⁾ On the cover HERMES Q2/Q4/Q4.3 cut-out dimension F standard 60 mm, optional 100 mm, on request up to 110 mm
 On the cover HERMES Q6.3 cut-out dimension F standard 25 mm, on request up to 110 mm

Stroke applicators HQ 4114, HQ 4116

Labels very small or midsized can be applied in real time from all sides.

The pad locates in front of the peel-off plate. It picks up a label while it is being printed. Powered by a short stroke cylinder, the pad is brought into position in horizontal direction. The label is transferred to a product by a stroke cylinder. The length of the stroke cylinder defines the maximum distance of a product to the peel-off plate.



Accessories

5.13 **Blow tube**

5.14 **Unit to regulate compressed air**



Stroke applicators	HQ 4114 L/R-200	HQ 4114 L/R-300	HQ 4114 L/R-400	HQ 4114 L/R-600	HQ 4116 L/R-200	HQ 4116 L/R-300	HQ 4116 L/R-400
State of a product at the moment a label is applied	at rest						
Label applications	from the top, from below, from the side						
Product heights	variable						
Short stroke cylinder, horizontal	mm						
Distance of a product to the bottom of the unit	up to mm						
Weight of applicator packaging excluded	5	5.5	7	9	5.5	6	7.5
Consumption of power	W max.						
Compressed air	bar						
Cycle rate ¹⁾	labels/min approx.						

¹⁾ Calculated using a stroke of 100 mm below the unit, labels 40 mm high, a print speed of 100 mm/s
If the height of the form pad exceeds 60 mm, the cover of HERMES Q must be adapted.

Form pad

Labels are precisely applied to cylindric objects, inclined or curved surfaces. Curved form pads prevent from blistering on very smooth and plane surfaces. 200° maximum label wrapping on cylindric objects



Transfer module			Form pad 4114, 4116 L/R 8800
Label widths	HERMES Q2	mm	10 - 58
	HERMES Q4/Q4.3	mm	10 - 114
	HERMES Q6.3	mm	50 - 174
Label heights		mm	8 - 80

Stroke turn applicator HQ 4214

Labels very small or midsized can be applied in real time from all sides whenever the unit is difficult to install.

The pad locates in front of the peel-off plate. It picks up a label while it is being printed. Powered by a rotary cylinder, the pad pivots into position by at most 180° in horizontal direction. The label is transferred to a product by a stroke cylinder. The length of the stroke cylinder defines the maximum distance of a product to the peel-off plate.



Accessories

- 5.13 **Blow tube**
- 5.14 **Unit to regulate compressed air**

Options

- 5.17 **Pressure-reducing valve**
- 5.18 **Pressure-reduced applicator**



Stroke turn applicator		HQ 4214 L/R-200	HQ 4214 L/R-300	HQ 4214 L/R-400
State of a product	at rest		■	
	in motion		only blow-on pad	
Label applications			from the top, from below, from the side	
Product heights	uniform		only blow-on pad	
	variable		all tamp-on pads	
Rotary angle, horizontal	90°, 0° 180° if labels are no more than 15 mm high		■	
Distance of a product to the bottom of the unit	up to mm	135	235	335
Weight of applicator	packaging excluded kg	5	5.5	7.5
Consumption of power	W max.		15	
Compressed air	bar		4.5	
Cycle rate ¹⁾	labels/min approx.		20	

¹⁾ calculated using a stroke of 100 mm below the unit, labels 40 mm high, a print speed of 100 mm/s



Tamp-on pad

Labels are precisely tamped on plane surfaces. Recessed levels are possible as well.

Tamp-on pad, providing a damping layer

When applying labels to hard surfaces, the noise level is reduced. It benefits also in cases of rough structures or little unevenness.

Tamp-on pad, providing a label stop

It enables small labels be applied exactly on spot to a product.

Blow-on pad

It benefits when labels have to be applied to sensitive surfaces or products in motion. Labels are blown on by a blast of air. Stroke cylinder adjustment enables bridging distances of 5 to 10 mm to the surface of a product.

			Tamp-on pad	Tamp-on pad, providing a damping layer	Tamp-on pad, providing a label stop	Blow-on pad
Transfer modules			4214 L/R 11 F	4214 L/R 12 F	4214 L/R 61 F	4214 L/R 2100
Label widths	HERMES Q2	mm	4 - 58	10 - 58	10 - 58	10 - 58
	HERMES Q4/Q4.3	mm			10 - 80	
Label heights	HERMES Q2	mm	4 - 40	8 - 40	4 - 40	10 - 40
	HERMES Q4/Q4.3	mm	8 - 40	8 - 40	8 - 40	10 - 40
Depth of a pad immersing F ¹⁾	up to mm		90	90	90	-

²⁾ On the cover HERMES Q2/Q4/Q4.3 cut-out dimension F standard 60 mm, optional 100 mm

Stroke applicator HQ 4414

Labels very small or mid-sized can be applied in real time from all sides. Positions to which labels shall be applied can be adjusted in directions x and y.

The pad locates in front of the peel-off plate. It picks up a label while it is being printed. Powered by two short stroke cylinders, the pad is brought into position. The label is transferred to a product by a stroke cylinder. The length of the stroke cylinder defines the maximum distance of a product to the peel-off plate.



Accessories

- 5.13 **Blow tube**
- 5.14 **Unit to regulate compressed air**

Options

- 5.17 **Pressure-reducing valve**
- 5.18 **Pressure-reduced applicator**

4.4



Stroke applicators	HQ 4414 L/R-200	HQ 4414 L/R-300	HQ 4414 L/R-400	
State of a product at the moment a label is applied	at rest	■		
Label applications	from the top, from below, from the side			
Product heights	variable	■		
Short stroke cylinders, horizontal	direction x mm	3 - 7		
	direction y mm	11 - 15		
Distance of a product to the bottom of the unit	up to mm	135	235	335
Weight of applicator	packaging excluded kg	5	5.5	6
Consumption of power	W max.	15		
Compressed air	bar	4.5		
Cycle rate ¹⁾	labels/min approx.	25		

¹⁾ calculated using a stroke of 100 mm below the unit, labels 40 mm high, a print speed of 100 mm/s



Tamp-on pad

Labels are precisely tamped on plane surfaces. Recessed levels are possible as well.



Tamp-on pad, providing a damping layer

When applying labels to hard surfaces, the noise level is reduced. It benefits also in cases of rough structures or little unevenness.



Tamp-on pad, providing a label stop

It enables small labels be applied exactly on spot to a product.

			Tamp-on pad	Tamp-on pad, providing a damping layer	Tamp-on pad, providing a label stop
			4414 L/R 11 F	4414 L/R 12 F	4414 L/R 61 F
Label widths	HERMES Q2	mm	4 - 58	10 - 58	10 - 58
	HERMES Q4/Q4.3	mm		10 - 114	
Label heights	HERMES Q2	mm	4 - 80	8 - 80	4 - 80
	HERMES Q4/Q4.3	mm		8 - 80	
Depth of a pad immersing F ²⁾		up to mm		120	

²⁾ On the cover HERMES Q2/Q4/Q4.3 cut-out dimension F standard 60 mm, optional 100 mm

Swing stroke applicator HQ 4514

Labels can be applied in real time from all sides on inner surfaces of profiles and pipes. Stroke cylinder adjustment enables labels be transferred exactly to their dedicated spots.

The pad locates in front of the peel-off plate. It picks up a label while it is being printed. Powered by a rotary cylinder, the pad pivots to the level on which the label shall be applied. The label is moved to the point of transfer by a stroke cylinder.



Accessories

5.13 Blow tube

5.14 Unit to regulate compressed air

4.5



Swing stroke applicators	HQ 4514 L/R-200	HQ 4514 L/R-300	HQ 4514 L/R-400
State of a product at the moment a label is applied	at rest	■	
Label applications	from the top, from below, from the side		
Product heights	uniform	■	
Pivot angle, vertical	120°		
Distance between the bottom of the unit and the upper label ending	up to mm 150 ²⁾	250 ²⁾	350 ²⁾
Weight of applicator	packaging excluded kg 6	6.5	7
Consumption of power	W max.	15	
Compressed air	bar	4.5	
Cycle rate ¹⁾	labels/min approx.	20	

¹⁾ calculated using a stroke of 100 mm below the unit, labels 40 mm high, a print speed of 100 mm/s

²⁾ depending from the height of a label



Blow-on pad

Labels are blown on a product surface by a blast of air, bridging a distance of 5 to 10 mm.

Transfer module			Blow-on pad 4514 L/R 2100
Label widths	HERMES Q2	mm	10 - 58
	HERMES Q4/Q4.3	mm	10 - 80
Label heights		mm	10 - 60

Flag applicator HQ 4712

Labels can be applied in real time from all sides precisely on round materials such as cables, hoses or pipes.

The pad locates in front of the peel-off plate. It picks up a label while it is being printed. The label is transferred to the spot of application by a stroke cylinder. A further cylinder guides the material all around the material using cam control. First, both endings of a label are stuck together. Then the label is tamped to the round material. The length of the stroke cylinder defines the maximum distance of a product to the peel-off plate.

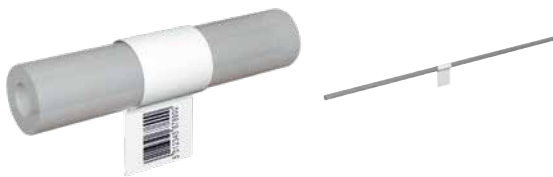

Accessories

5.13 **Blow tube**

5.14 **Unit to regulate compressed air**

Flag applicator		HQ 4712
State of a product at the moment a label is applied	at rest	■
Label applications		from the top, from below, from the side rotated vertically: 0 - 180° clockwise (request in case of other rotations)
Product heights	uniform	■
Distance of a product to the bottom of the unit using a cylinder stroke of 300	at least mm up to mm	70 260
Depth of pliers immersing	mm	55
Offset P	up to mm	1.0 ²⁾
Weight of applicator	packaging excluded kg	8
Consumption of power	W max.	15
Compressed air	bar	4.5
Cycle rate, printing and applying only ³⁾	labels/min approx.	15

¹⁾ Processing labels 50 to 58 mm wide requires a spacer.

²⁾ depending from the quality of a label

³⁾ calculated using a print speed of 100 mm/s

⁴⁾ Flag on product requires >60 mm clearance on one side without components, bend or step

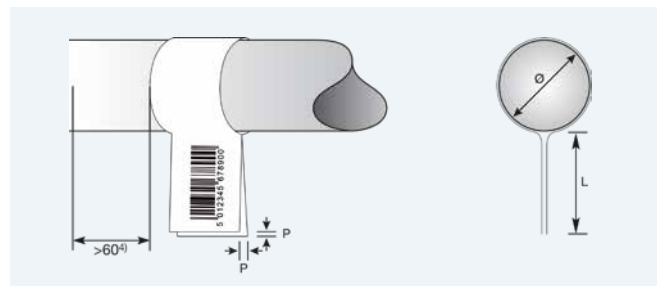
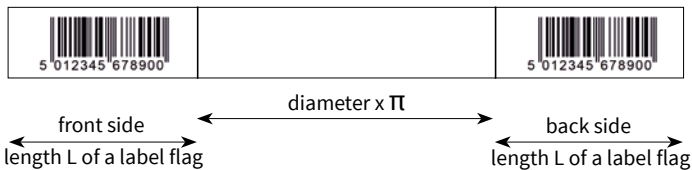

Transfer module		Form pad	
		4712 L 300	
Label widths	HERMES Q4L/Q4.3L	mm	50 ¹⁾ - 100
Label heights		mm	10 - 50
Diameter		mm	3 - 16

Front side applicators HQ 3014, HQ 3016

Labels can be applied in real time from the top or the side to packages in motion. Front sides or back sides of a package are preferred.

The pad locates in front of the peel-off plate. It picks up a label while it is being printed. The label is transferred to a product with the help of a rotary cylinder. The package is detected by a sensor and the pivot arm with the pad returned to its initial position.

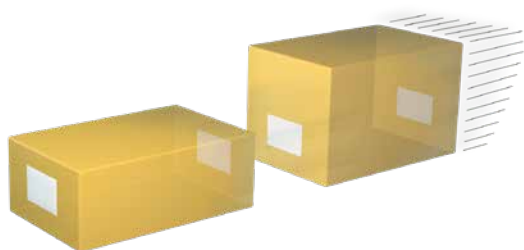

Accessories

5.13 **Blow tube**

5.14 **Unit to regulate compressed air**

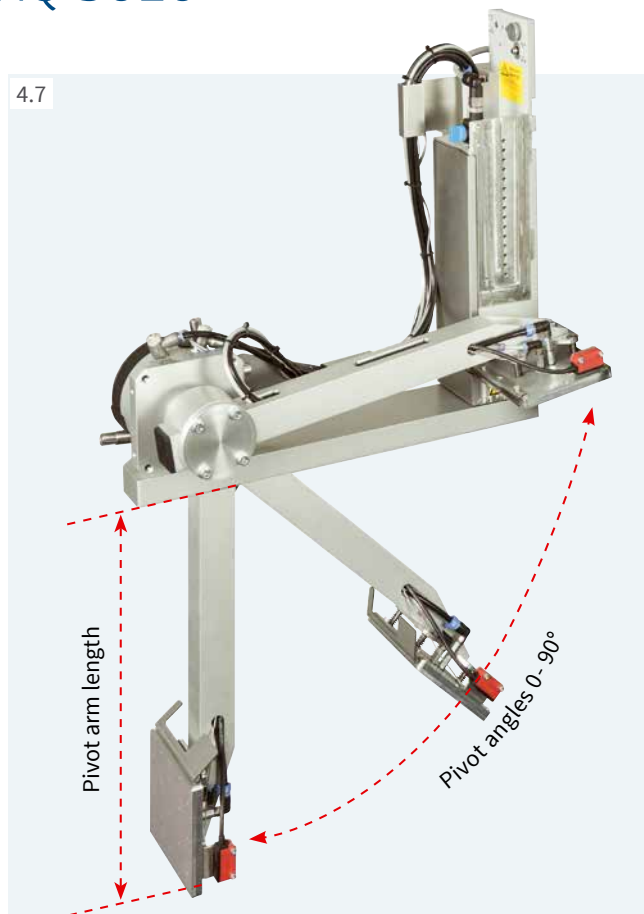

Front side applicators		HQ 3014 L/R-200	HQ 3014 L/R-300	HQ 3014 L/R-400	HQ 3014 L/R-600	HQ 3016 L/R-200	HQ 3016 L/R-300	HQ 3016 L/R-400	HQ 3016 L/R-600
State of a package	at rest				■				
	at the moment a label is applied					■			
Label applications	in motion	from the top, from the side, from the front, from the back							
Package heights	variable	■							
Pivot arm lengths ¹⁾	mm	200	300	400	600	200	300	400	600
Pivot angles		0 - 90°							
Weight of applicators	packaging excluded kg	9	9.5	10.5	11.5	9.5	10	11	12
Consumption of power	W max.	15							
Compressed air	bar	4,5							
Cycle rate ²⁾	labels/min approx.	15							

¹⁾ Pivot arm length defines the spot of a label (lower margin) to be reached at 90° below a HERMES Q footprint.

²⁾ calculated using a pivot arm 200 mm long, labels 100 mm high, a print speed of 100 mm/s



Tamp-on pad

Labels are precisely tamped on plane surfaces. Recessed levels are possible as well.



Tamp-on pad, spring-mounted

Labels can be applied to surfaces inclined by a maximum of 15°. Heights within the area of a label may vary by 10 mm at most.



Blow-on pad

Labels are blown on a package surface by a blast of air, bridging a distance of 5 to 10 mm.

Transfer modules			Tamp-on pad 3014, 3016 L/R 1100	Tamp-on pad, spring-mounted 3014, 3016 L/R 3100	Blow-on pad 3014 L/R 2100
Label widths	HERMES Q4/Q4.3	mm	25 - 114	80 - 114	25 - 114
	HERMES Q6.3	mm	25 - 174	80 - 174	-
Label heights	HERMES Q4/Q4.3	mm	8 - 250	80 - 250	10 - 100
	HERMES Q6.3	mm	25 - 250	80 - 250	25 - 100

Stroke applicators HQ 4014, HQ 4016

Labels can be applied in real time from all sides to packages. The type of pad defines whether a package has to be at rest or can be in motion at the time a label is applied.

The pad locates in front of the peel-off plate. It picks up a label while it is being printed. The label is transferred to a package with the help of a stroke cylinder. The package is detected by a sensor and the pad returned to its initial position. The length of the stroke cylinder defines the maximum distance of a package to the peel-off plate.



Accessories

5.13 **Blow tube**

5.14 **Unit to regulate compressed air**

Options

5.17 **Pressure-reducing valve**

5.18 **Reduced-force applicator**

4.8



Stroke applicators		HQ 4014L/R-200	HQ 4014L/R-300	HQ 4014L/R-400	HQ 4014L/R-600	HQ 4016L/R-200	HQ 4016L/R-300	HQ 4016L/R-400	HQ 4016L/R-600
Package heights	variable	■							
State of a package at the moment a label is applied	at rest	■							
Label applications		from the top, from below, from the side			from the top, from below	from the top, from below, from the side			from the top, from below
Distance of a package to the bottom of the unit	up to mm	130	230	330	530	130	230	330	530
Weight of applicator	packaging excluded kg	5	5	7	9	5	5.5	7.5	9.5
Consumption of power	W max.	15							
Compressed air	bar	4,5							
Cycle rate ¹⁾	labels/min approx.	25							

¹⁾ calculated using a stroke of 100 mm below the unit, labels 100 mm high, a print speed of 100 mm/s



Tamp-on pad

Labels are precisely tamped on plane surfaces. Recessed levels are possible as well.

Universal pad

Labels can be tamped on plane surfaces. Drilled holes are provided in gaps of 5 mm to suck a label. The holes are covered by a sliding foil, but can be opened according to the size of a label using a punching tool. Delivery includes two extra foils.

Tamp-on pad, spring-mounted

Labels can be applied to surfaces inclined by a maximum of 15°. Heights within the area of a label may vary by 10 mm at most.

Universal pad, spring-mounted

Labels can be applied to surfaces inclined by a maximum of 15°. Heights in the area of a label may vary by 10 mm at most. To suck a label, drilled holes are provided in gaps of 5 mm and covered by a sliding foil. Delivery includes two extra foils.

			Tamp-on pad	Universal pad	Tamp-on pad, spring-mounted	Universal pad, spring-mounted
Transfer modules			4014, 4016 L/R 11 F	4014 L/R 1100	4014, 4016 L/R 3100	4014 L/R 3100
Label widths	HERMES Q4/Q4.3	mm	20 - 114	75 / 90	80 - 114	116 / 116
	HERMES Q6.3	mm	50 - 174	-	80 - 174	-
Label heights	HERMES Q4/Q4.3	mm	20 - 210	60 / 90	80 - 210	102 / 152
	HERMES Q6.3	mm	25 - 210	-	80 - 210	-
Depth of a pad immersing F ²⁾		up to mm	140	-	-	-

²⁾ On the cover HERMES Q2/Q4/Q4.3 cut-out dimension F standard 60 mm, optional 100 mm, on request up to 120 mm
On the cover HERMES Q6.3 cut-out dimension F standard 25 mm, on request up to 120 mm

Stroke applicators HQ 4014, HQ 4016

Labels can be applied in real time from all sides to packages. The type of pad defines whether a package has to be at rest or can be in motion at the time a label is applied.

The pad locates in front of the peel-off plate. It picks up a label while it is being printed. The label is transferred to a package with the help of a stroke cylinder. The package is detected by a sensor and the pad returned to its initial position. The length of the stroke cylinder defines the maximum distance of a package to the peel-off plate.

Accessories

5.13 Blow tube

5.14 Unit to regulate compressed air

Options

5.17 Pressure-reducing valve

5.18 Pressure-reduced applicator

4.8



Stroke applicators		HQ 4014L/R-200	HQ 4014L/R-300	HQ 4014L/R-400	HQ 4014L/R-600	HQ 4016L/R-200	HQ 4016L/R-300	HQ 4016L/R-400	HQ 4016L/R-600
State of a package at the moment a label is applied	at rest	Blow-on pad, Corner-wrap pad							
	in motion	Blow-on pad, Roll-on pad							
Label applications	from the top	Blow-on pad, Roll-on pad, Corner-wrap pad							
	from below	Blow-on pad, Roll-on pad							
	from the side	Blow-on pad, Roll-on pad				-	Blow-on pad, Roll-on pad		
Distance of a package to the bottom of the unit	Blow-on pad up to mm	140	240	340	540	-	-	-	-
	Roll-on pad up to mm	160	260	360	560	160	260	360	560
	Corner-wrap pad up to mm	100	200	300	500	-	-	-	-
Package heights	uniform	Blow-on pad							
	variable	Blow-on pad, Corner-wrap pad							
Weight of applicator	packaging excluded kg	5	5	7	9	5.5	5.5	7.5	9,5
Consumption of power	W max.	15							
Compressed air	bar	4,5							
Cycle rate ¹⁾	labels/min approx.	25							

¹⁾ calculated using a stroke of 100 mm below the unit, labels 100 mm high, a print speed of 100 mm/s



Blow-on pad

It benefits when labels have to be applied to sensitive surfaces or packages in motion. Labels are blown on by a blast of air. Stroke cylinder adjustment enables bridging distances of 5 to 10 mm to the surface of a package.



Roll-on pad

Labels are rolled on plane surfaces while these packages are in motion.



Corner-wrap pad

Labels are applied to a package on two sides adjacent to one another. One half of a label is applied to the top of a package. Then the other half of the label is rolled on.

Transfer modules			Blow-on pad 4014 L/R 2100	Roll-on pad 4014, 4016 L/R 4100	Corner-wrap pad 4014 L/R 5100
Label widths	HERMES Q4/Q4.3	mm	20 - 114	25 - 114	20 - 114
	HERMES Q6.3	mm	provided upon request	50 - 174	-
Label heights	HERMES Q4/Q4.3	mm	20 - 100	80 - 250	60 - 210
	HERMES Q6.3	mm	provided upon request	80 - 250	-

Stroke applicators HQ 4024

- As much as 90 percent savings of compressed air
- Labels applied onto variable heights using one tamp pad

Labels are applied in real time onto packagings of different heights.

A spring-mounted print pad enables labels be applied reliably even onto inclined surfaces. Three vacuum pads are provided for labels 40 mm to 100 mm high, 150 mm and 200 mm. Label widths are 50 mm to 105 mm in each case.

Labels are sucked without supporting air by an electrically driven fan. Only the stroke cylinder requires compressed air.



Accessories

5.14 Unit to regulate compressed air

Options

5.17 Pressure-reducing valve



Stroke applicators		HQ 4024 L/R-200	HQ 4024 L/R-300	HQ 4024 L/R-400	HQ 4024 L/R-600
Distance of a package to the bottom of the unit	up to mm	135	235	335	535
Package heights	variable	■			
Alternation in the heights of packages	mm max.	100	200	300	500
Label applications		from the top, from below, from the side			from the top
State of a package at the moment a label is applied	at rest	■			
Controls	Sensor 1	initial / upper end position			
	Sensor 2	label on vacuum pad			
	Sensor 3	label application / lower end position			
Consumption of power	W max.	30			
Compressed air	bar	4.5			
Cycle rate ¹⁾	labels/min approx.	30			

¹⁾ calculated using a stroke of 100 mm below the unit, labels 40 mm high, a print speed of 100 mm/s

Vacuum pad

Labels are precisely tamped on plane surfaces.

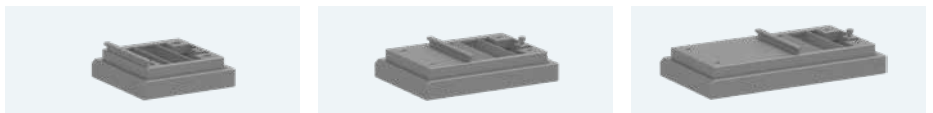

Vacuum pad			4024-3000 105 x 100	4024-3000 105 x 150	4024-3000 105 x 200
Label	Width	mm	50 - 105	50 - 105	50 - 105
	Height	mm	40 - 100	80 - 150	120 - 200
	Thickness	µm	110	110	110

Stroke blow applicator HQ 4614

Labels can be applied in real time from all sides on packages of various heights in motion.

The pad locates in front of the peel-off plate. It picks up a label while it is being printed. Powered by a stroke cylinder and detected by a sensor, the pad moves to a spot approx. 10 mm above a package. The length of the stroke cylinder defines the maximum difference in terms of package heights.



Accessories

5.13 **Blow tube**

5.14 **Unit to regulate compressed air**

4.10



Stroke blow applicator		HQ 4614 L/R-200	HQ 4614 L/R-300	HQ 4614 L/R-400
Distance of a package to the bottom of the unit	up to mm	140	240	340
Package heights	variable	■		
Label applications		from the top, from below, from the side		
State of a package at the moment a label is applied	at rest in motion	■ ■	■ ■	■ ■
Weight of applicator	packaging excluded kg	n.a.	5.5	6.5
Consumption of power	W max.		15	
Compressed air	bar		4.5	
Cycle rate ¹⁾	labels/min approx.		25	

¹⁾ calculated using a stroke of 100 mm below the unit, labels 100 mm high, a print speed of 100 mm/s

Blow-on pad

Labels are blown on a package surface by a blast of air, bridging a distance of 5 to 10 mm.



Blow-on pad			4614L/R-2100 B x H
Label widths	HERMES Q4/Q4.3	mm	20 - 114
	HERMES Q6.3	mm	provided upon request
Label heights	HERMES Q4/Q4.3	mm	20 - 100
	HERMES Q6.3	mm	provided upon request

Demand modules HQ 5112, HQ 5114, HQ 5116

Series of labels can be applied from all sides to packages in motion. The position to which apply a label can be defined on the dispenser tongue using a guide roller.

While a label is applied, the next one is printed simultaneously. Make sure the speed of the conveyor belt corresponds to the print speed.

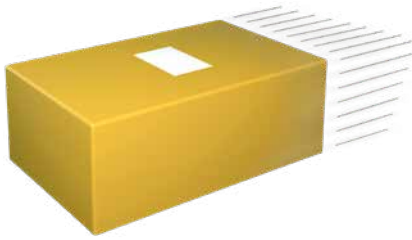

Draw roller, made of steel
obligatory when operating
a demand module

Demand module		HQ 5112 L/R	HQ 5114 L/R	HQ 5116 L/R
Label widths	HERMES Q2	10 - 58	-	-
	HERMES Q4/Q4.3	-	25 - 114	-
	HERMES Q6.3	-	-	46 - 174
Label heights	mm	10 - 250	25 - 250	
Distance of the print line to the peel-off plate	mm		400 - 600	
State of a package at the moment a label is applied	in motion	■		
Label applications		from the top, from below, from the side		
Package heights	uniform	■		
Distance of a package to the bottom of the unit	mm	80		
Package speeds	mm/s	must correspond to the print speed / 50 - 250 in steps of 25		
Weight of module	packaging excluded kg	not specified	3	7
Consumption of power	W max.	not specified		
Cycle rate ¹⁾	labels/min approx.	60		

¹⁾ calculated using labels 100 mm high and a print speed of 100 mm/s

Vacuum belt applicators HQ 5314, HQ 5316

Labels can be applied in real time from all sides on plane surfaces to packages in motion.

The applicator locates in front of the peel-off plate. Printed labels are conveyed by a vacuum belt to the point of transfer to a package. Applying a label is triggered by an external signal.



Vacuum belt applicators	HQ 5314-2	HQ 5314-3	HQ 5314-4	HQ 5316-2	HQ 5316-3	HQ 5316-4		
Label applications	on plane surfaces							
Directions to which dispense labels	left and right							
Label widths	HERMES Q4/Q4.3	mm	20 - 114	20 - 114	20 - 114	-	-	-
	HERMES Q6.3	mm	-	-	-	46 - 174	46 - 174	46 - 174
Label heights		mm	60 - 256	60 - 356	60 - 456	60 - 256	60 - 356	60 - 456
State of a package at the moment a label is applied	in motion							
Label applications	from the top, from below, from the side							
Package heights	uniform							
Package speeds	up to m/s							
Gap between packages	at least m							
Vacuum belt speed ¹⁾	mm/s							
Weight of applicator	packaging excluded kg							
Consumption of power	W max.							
Cycle rate ²⁾	labels/min up to							
Distance of a label to the conveyor belt, when applying from the side	mm							

¹⁾ The speed of a package must be at least as high as the speed of the vacuum belt.

²⁾ calculated using labels 100 mm high and a print speed of 250 mm/s

Vacuum belt applicators HQ 5414, HQ 5416

Labels can be applied in real time from the top or from the side on cylindrical surfaces or corner-wrap to packages in motion.

The applicator locates in front of the peel-off plate. Printed labels are conveyed by a vacuum belt to the point of transfer to a package. Applying a label is triggered by an external signal.



Vacuum belt applicators			HQ 5414-3	HQ 5414-4	HQ 5416-3	HQ 5416-4
Label applications			on cylindrical surfaces and corner-wrap			
Directions to which dispense labels			left and right			
Label widths	HERMES Q4/Q4.3	mm	20 - 114	20 - 114	-	-
	HERMES Q6.3	mm	-	-	46 - 174	46 - 174
Label heights		mm	80 - 356	80 - 456	80 - 356	80 - 456
State of a package at the moment a label is applied		in motion	■			
Label applications			from the top, from the side			
Package heights	uniform		■			
	variable		■			
Package speeds		up to m/s	0.3			
Gap between packages		at least m	0.5			
Steadiness identified at the point a label is transferred			$F^1) = 30 \text{ N}$			
Corner-wrap label applications		up to mm	$X = 160$			
Vacuum belt speed ²⁾		mm/s	100 - 300			
Weight of applicator	packaging excluded	kg	7	7	8.5	8.5
Consumption of power		W max.	90			
Cycle rate ³⁾		labels/min up to	15			
Distance of a label to the conveyor belt, when applying from the side		mm	$Y = 20$			

¹⁾ F = force required to make the vacuum belt pivot

²⁾ The speed of a package must be at least as high as the speed of the vacuum belt.

³⁾ calculated using labels 100 mm high and a print speed of 250 mm/s

Demand table HQ 5714

The demand table is a transfer module for the HERMES Q 4 in the left-hand version and enables printed and predisposed labels to be picked up by a robot. The labels are at rest during the pick-up process.

After printing and dispensing, the labels are placed over the extended Peel-off plate, adhesive side facing the dispensing table, ready for transfer to the robot stamp. The labels are at rest during removal. After removal, an automatic retraction can be performed on the printer.

The orientation of assembly of the system is designed for vertical removal.

Optionally, the printed label can be verified by a Scanner (provided by the customer) before it is transferred to the tamp pad. To support the label transfer to the print stamp, an optional chamber system with supporting air holes can be used.



Demand table		HQ 5714L-100
Label widths	mm	38-114
Label heights	mm	18-100
Orientation		left
Label during acceptance		at rest
Label material		Paper, plastics with release
Label application tolerance	mm	± 0.5
Compressed air	bar	no compressed air; 4.5 bar is an option
Cycle rate	labels/min up to	30

Air jet box HQ 6114

Labels can be applied to packages in motion or at rest. Each label is sucked by a fan and blown off by a powerful blast of air coming through aligned nozzles. Depending from the size of a label, a maximum distance of 200 mm can be bridged between a package and the peel-off plate.

1 Template

to cover all the holes sucking or blowing off air outside a label

By holes pre-scored on an 8 x 8 mm pattern, a template can be adapted easily to the size of a label. By sliding in a template between the suction block and rails, the surface outside a label is covered. Scope of delivery includes five templates.

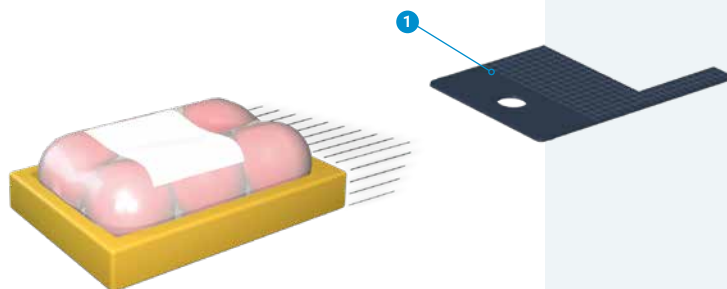

4.15



Accessories

5.13 **Blow tube**

5.16 **Unit to regulate compressed air, providing a shut-off valve**

Air jet box		HQ 6114 L/R	
Label widths	HERMES Q4/Q4.3 mm	50-114	smaller sizes can be provided on request
Label heights	mm	50-125	smaller sizes can be provided on request
State of a package	at rest		■
at the moment a label is applied	in motion		■
Label applications		from the top, from below, from the side	
Package heights	variable		■
Distance of a package to the peel-off plate	up to mm		200
Weight of air jet box	packaging excluded kg		4
Consumption of power	W max.		90
Compressed air	bar		4.5
Cycle rate ¹⁾	labels/min up to		100

¹⁾ calculated using labels 50 mm high, a print speed of 250 mm/s, a blast of air lasting 100 ms, with packages located 100 mm to the peel-off plate.

Accessories provided for applicators

5.13



Blow tube

to provide support air. To assist label transfer, the label is blown from below to the pad.

Provided for 2", 4" or 6" label applications

5.14



Unit to regulate compressed air

4.5 bar default setting

Provided in a left-hand or right-hand design

Delivery includes a fine filter, a pressure control valve with a display, a hose to connect to an applicator's compressed air input and material to assemble the unit to a chassis or a bracket.

5.16



Unit to regulate compressed air, providing a shut-off valve

to vent a hose line subsequent to the unit

Provided in a left-hand or right-hand design

Examples how to assemble a unit to regulate compressed air

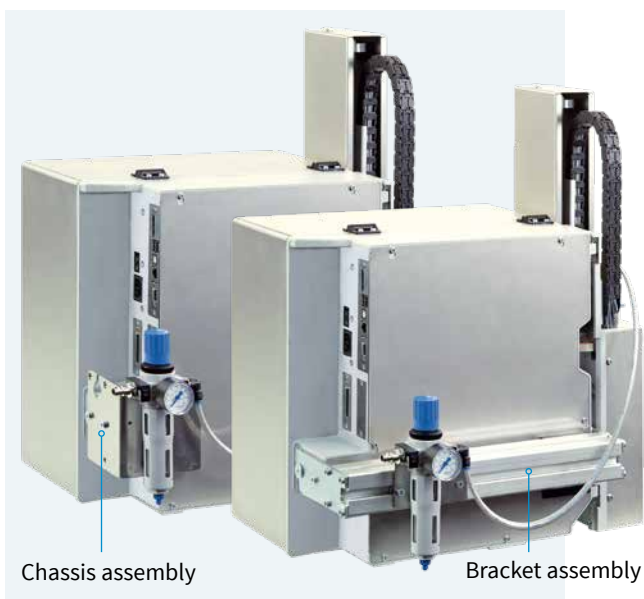

Chassis assembly

Bracket assembly

Options provided for applicators

5.17



Pressure-reducing valve

It reduces the pressure exerted by the stroke cylinder to a product.

5.18



Pressure-reduced applicator

It has been designed for manual workstations missing a protective cover. The cylinder diameter is reduced to 12 mm. To prevent from injuries, a safety valve limits compressed air to a maximum of 4.8 bar.

Tools for assembling HERMES Q

Pos.	Designation	1.1	1.2		1.3
		HERMES Q2	HERMES Q4.3	HERMES Q4	HERMES Q6.3
6.1	Adapter plate	<input type="checkbox"/>	<input type="checkbox"/>	<input type="checkbox"/>	<input type="checkbox"/>
6.2	Profiles 40, 80, 120, 160, 200, 300 mm	<input type="checkbox"/>	<input type="checkbox"/>	<input type="checkbox"/>	<input type="checkbox"/>
6.3	Base plate 500 x 255 mm	<input type="checkbox"/>	<input type="checkbox"/>	<input type="checkbox"/>	-
6.4	Base plate with XY Stop and product sensor	<input type="checkbox"/>	<input type="checkbox"/>	<input type="checkbox"/>	-



Mount

to install on a table or to a production line.
Provided in a left-hand or right-hand design

The size of the mount can be adapted to an application.

6.1



1 Adapter plate

to fix a label application system.

Alternatively, it can be assembled directly to a production line, using the adapter plate with a profile.

6.2



2 Profile

square aluminum; 40, 80, 120, 160, 200, 30 mm are standards, further lengths can be provided on request

6.3



3 Base plate

to fix the product jig; 500 x 255 mm by default

6.4



4 Base plate with XY stop and product sensor

Standard size 500 x 255 mm

Tools for assembling HERMES Q

Pos.	Designation	1.1	1.2		1.3
		HERMES Q2	HERMES Q4.3	HERMES Q4	HERMES Q6.3
6.5	Bracket	<input type="checkbox"/>	<input type="checkbox"/>	<input type="checkbox"/>	<input type="checkbox"/>
6.6	Clamped joint designed for a 50 x 50 mm profile	<input type="checkbox"/>	<input type="checkbox"/>	<input type="checkbox"/>	<input type="checkbox"/>
6.7	Flanged joint designed for a 50 x 50 mm profile	<input type="checkbox"/>	<input type="checkbox"/>	<input type="checkbox"/>	<input type="checkbox"/>
6.8	Floor stand 1601	<input type="checkbox"/>	<input type="checkbox"/>	<input type="checkbox"/>	<input type="checkbox"/>
6.9	Floor stand 1602	<input type="checkbox"/>	<input type="checkbox"/>	<input type="checkbox"/>	<input type="checkbox"/>
6.10	Floor stand 1201	<input type="checkbox"/>	<input type="checkbox"/>	<input type="checkbox"/>	<input type="checkbox"/>



Bracket
to assemble to a floor stand

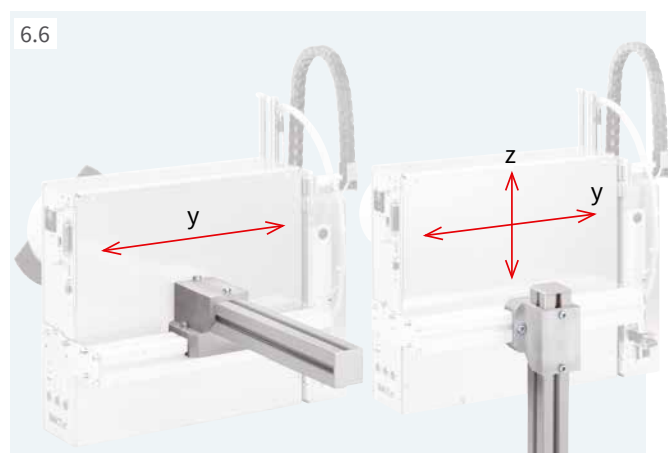

Clamped joint designed for a 50 x 50 mm profile
to move in horizontal or vertical direction

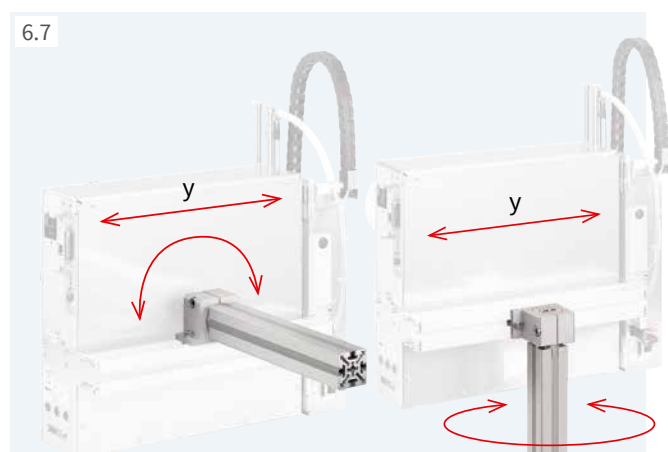

Flanged joint designed for a 50 x 50 mm profile
to move in horizontal direction or rotate around an axis

Floor stands provided for HERMES Q

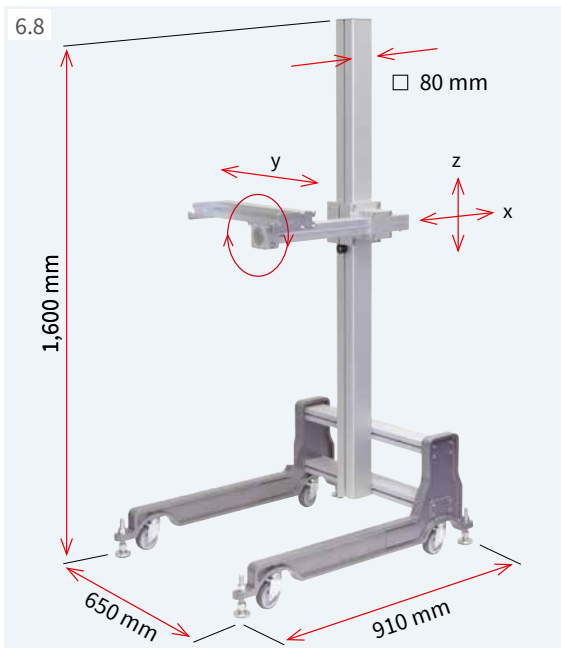

HERMES Q can be installed to a production line and aligned in three axes to the product to label. Pivoting is also possible.

Floor stand 1601

It benefits when operating HERMES Q in different production lines. Mobility is provided. At the place of operation, the floor stand can be fixed with the help of feet to adjust.

Floor stand	1601
Base frame	castors, feet
Adjustment of heights and depths	screw clamping
Load if offset is 500 mm	up to kg
Weight	kg

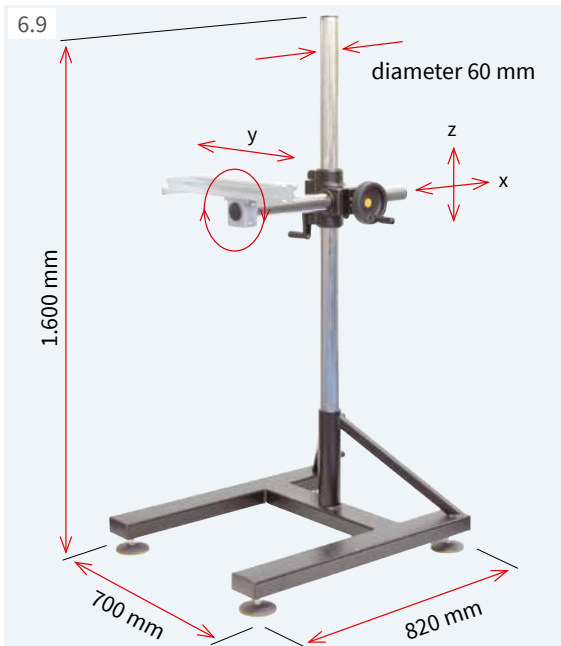

Floor stand 1602

It benefits if positions to apply labels are changing frequently in terms of heights and depths. HERMES Q can be aligned in directions x and z to a product using a toothed rack.

Floor stand	1602
Base frame	feet
Adjustment of heights and depths	toothed rack, crank toothed rack, handwheel
Load if offset is 500 mm	up to kg
Weight	kg

Examples how to assemble to a stand

Applying labels in direction of transport
from the top from the side

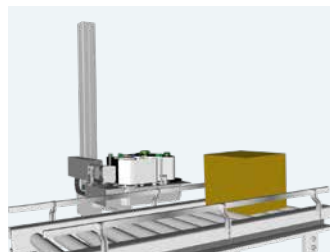
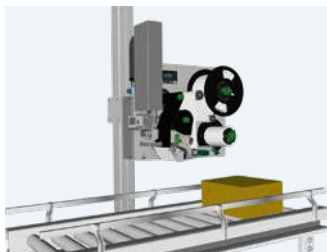

Applying labels crosswise the direction of transport
from the top from the side

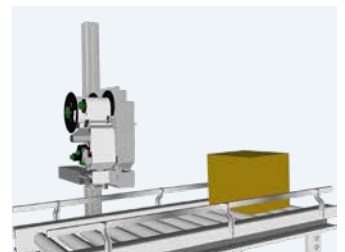
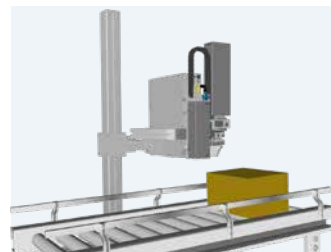

HERMES Q floor stand

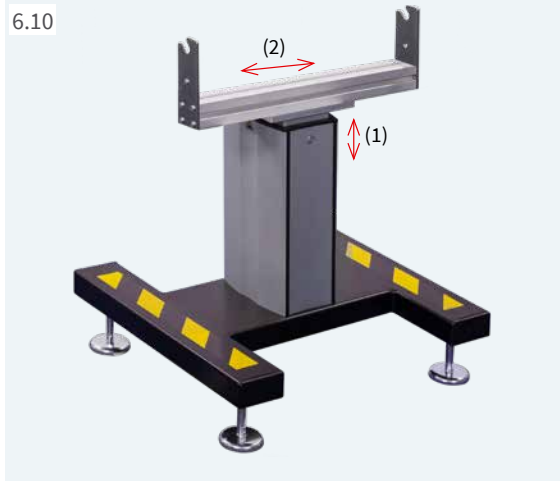

Floor stand 1201

to assemble HERMES Q horizontally in a production line.

The height can be adjusted continuous using an integral spindle.

A unit to regulate compressed air can be assembled to the bracket, so can a warning light.

Floor stand		1201
Feet to adjust	by mm	± 15
Load	up to kg	75
(1) Lower label margin-floor ¹⁾	mm	720-960
(2) Depth along direction of transport	mm	± 100
Weight	approx. kg	40

¹⁾ further dimensions can be provided on request

HERMES Q delivery program

Label printers L

Pos.	Part no.	Designation
1.1	6010003	Label printer HERMES Q2L/300-2
	6010004	Label printer HERMES Q2L/600-2
1.2	6010005	Label printer HERMES Q4L/300-2
	6010006	Label printer HERMES Q4L/600-2
	6010007	Label printer HERMES Q4.3L/200-2
	6010008	Label printer HERMES Q4.3L/300-2
1.3	6010009	Label printer HERMES Q6.3L/200-2
	6010010	Label printer HERMES Q6.3L/300-2
1.1	6010011	Label printer HERMES Q2L/300-3
	6010012	Label printer HERMES Q2L/600-3
1.2	6010013	Label printer HERMES Q4L/300-3
	6010014	Label printer HERMES Q4L/600-3
	6010015	Label printer HERMES Q4.3L/200-3
	6010016	Label printer HERMES Q4.3L/300-3
1.3	6010017	Label printer HERMES Q6.3L/200-3
	6010018	Label printer HERMES Q6.3L/300-3

xxxxxxx.250 if HERMES Q provides options

Label printers R

Pos.	Part no.	Designation
1.1	6010023	Label printer HERMES Q2R/300-2
	6010024	Label printer HERMES Q2R/600-2
1.2	6010025	Label printer HERMES Q4R/300-2
	6010026	Label printer HERMES Q4R/600-2
	6010027	Label printer HERMES Q4.3R/200-2
	6010028	Label printer HERMES Q4.3R/300-2
1.3	6010029	Label printer HERMES Q6.3R/200-2
	6010030	Label printer HERMES Q6.3R/300-2
1.1	6010031	Label printer HERMES Q2R/300-3
	6010032	Label printer HERMES Q2R/600-3
1.2	6010033	Label printer HERMES Q4R/300-3
	6010034	Label printer HERMES Q4R/600-3
	6010035	Label printer HERMES Q4.3R/200-3
	6010036	Label printer HERMES Q4.3R/300-3
1.3	6010037	Label printer HERMES Q6.3R/200-3
	6010038	Label printer HERMES Q6.3R/300-3

xxxxxxx.250 if HERMES Q provides options

Scope of HERMES Q label printer delivery

HERMES Q label printer
Power cable Type E+F, 1.8 m
Connecting USB cable, 1.8 m
Assembly instructions DE/EN

Provided online



<https://setup.cab.de/en>

Assembly instructions DE/EN/FR
Configuration manuals DE/EN/FR
Service manuals DE/EN
Spare parts lists DE/EN
Programming manual EN
Windows printer drivers certified WHQL for
Windows 10 Server 2016
Windows 11 Server 2019
Server 2022
Apple Mac OS X printer drivers DE/EN/FR
Linux printer drivers DE/EN/FR
cablabel S3 Lite software
cablabel S3 Viewer
Database Connector

Options

Pos.	Part no.	Designation
3.1	6010860.250	Automatic ribbon saving 4L
	6010861.250	Automatic ribbon saving 6L
3.2	6010862.250	Automatic ribbon saving 4R
	6010863.250	Automatic ribbon saving 6R
3.2	6010960.250	UHF RFID/4/6.3L RS module
	6010962.250	UHF RFID/4/6.3L HS module
3.2	6010970.250	UHF RFID/4/6.3R RS module
	6010972.250	UHF RFID/4/6.3R HS module
3.3	6010591.xxx	Label unwinder K40/2-2
	6010592.xxx	Label unwinder K40/4-2
	6010593.xxx	Label unwinder K40/6-2
	6010594.xxx	Label unwinder K40/2-3
	6010595.xxx	Label unwinder K40/4-3
3.4	6010596.xxx	Label unwinder K40/6-3
	5961406.xxx	Adapter 40/50
3.5	5961262.xxx	Adapter 76/100
	6010586.xxx	Spacer Q L-2
3.6	6010590.xxx	Spacer Q R-2
	6010905.xxx	Spacer Q L-3
	6010906.xxx	Spacer Q R-3
3.7	5961650.xxx	Margin stop 10
	6010500.xxx	Cover 2L F60
3.8	6010933.xxx	Cover 2L F100
	6010501.xxx	Cover 4L F60
	6010937.xxx	Cover 4L F100
	6010502.xxx	Cover 6L F25
	6010503.xxx	Cover 2R F60
	6010939.xxx	Cover 2R F100
	6010504.xxx	Cover 4R F60
	6010941.xxx	Cover 4R F100
	6010505.xxx	Cover 6R F25
	3.9	6010840.xxx
6010841.xxx		Print head pressure system 4L
6010842.xxx		Print head pressure system 6L
6010843.xxx		Print head pressure system 2R
6010844.xxx		Print head pressure system 4R
6010845.xxx		Print head pressure system 6R
3.10	6010557.xxx	Extended peel-off plate (+10 mm) 2L
	6010558.xxx	Extended peel-off plate (+10 mm) 4L
	6010559.xxx	Extended peel-off plate (+10 mm) 6L
	6010563.xxx	Extended peel-off plate (+10 mm) 2R
	6010564.xxx	Extended peel-off plate (+10 mm) 4R
3.11	6010565.xxx	Extended peel-off plate (+10 mm) 6R
	5954978.xxx	Print roller DRS2
3.11	5954985.xxx	Print roller DRS4
	5954979.xxx	Print roller DRS6
	5961640.xxx	Antistatic brush 2L
3.12	5961644.xxx	Antistatic brush 4L
	5961642.xxx	Antistatic brush 2R
	5961646.xxx	Antistatic brush 4R
3.13	5961750.xxx	Draw roller ZS2
	5961751.xxx	Draw roller ZS4
	5961752.xxx	Draw roller ZS6
3.14	5591816.xxx	Interface for plugging an external label sensor
3.15	6010520.xxx	2 port Ethernet switch 10/100 Mbit/s
3.16	5977487.xxx	Label sensor L, modified
	6010498.xxx	Label sensor R, modified

xxx - .250 assembled to the printer
.001 delivered separately



Informations are available also on the Internet:
www.cab.de/en/hermesq

HERMES Q delivery program

Accessories





Pos.	Part no.	Designation
2.1	 5977370	SD memory card
2.2	 5977730	USB memory stick
2.3	 5978912	USB WLAN stick 2.4 GHz 802.11b/g/n
2.4	 5977731	USB WLAN stick including a rod antenna 2.4 GHz 802.11b/g/n + 5 GHz a/n/ac
2.6	 5970071	Product sensor, 3 pins
2.7	 5964300	Product sensor, 25 pins
2.8	 5917651	I/O interface connector SUB-D, 25 pins
2.9	 6010560	Warning light
2.10	 6010186	External operation panel
	5907718.850	Connecting USB cable, 1.8 m
	5907730.850	Connecting USB cable, 3 m
	5907750.850	Connecting USB cable, 5 m
	5907760.850 5907765.850	Connecting USB cable, 11 m Connecting USB cable, 16 m
2.11	 5948205	Label selection - I/O box
2.12	 5955710	Hand switch TR2
2.13	 5955711	Foot switch
2.14	 5550818	Connecting RS232 C cable 9/9 pins, 3 m
2.15	 on request	Scanner CC200

Label software

Pos.	Part no.	Designation
7.6	Bundle	cablabel S3 Lite (download on cab.de/en)
	5588001	cablabel S3 Pro, 1 WS
	5588100	cablabel S3 Pro, 5 WS
	5588101	cablabel S3 Pro, 10 WS
	5588150	cablabel S3 Pro, 1 additional licence
	5588151	cablabel S3 Pro, 4 additional licences
	5588152	cablabel S3 Pro, 9 additional licences
	5588002	cablabel S3 Print, 1 WS
	5588105	cablabel S3 Print, 5 WS
	5588106	cablabel S3 Print, 10 WS
	5588155 5588156 5588157	cablabel S3 Print, 1 additional licence cablabel S3 Print, 4 additional licences cablabel S3 Print, 9 additional licences
	in preparation	cablabel S3 Print Server
7.10	9008486	Programming manual EN, printed copy

Scopes of delivery, design and technical specifications correspond to the date of the printing. Subject to change. The data provided in the catalog do not represent any warranty or guarantee.

Wear parts















Pos.	Part no.	Designation
	5977384.001	Print head 2/300
	5977385.001	Print head 2/600
	5977444.001	Print head 4/300
	5977380.001	Print head 4/600
	5977382.001	Print head 4.3/200
	5977383.001	Print head 4.3/300
	5977386.001	Print head 6.3/200
	5977387.001	Print head 6.3/300
	5954102.001	Print roller DR2
	5954180.001	Print roller DR4
	5954245.001	Print roller DR6
	5961015.001	Draw roller ZR2
	5961298.001	Draw roller ZR4
	5961220.001	Draw roller ZR6
Pos.	Part no.	OM operation, RFID antenna assembled
	5987177.001	Print head 4.3/200 RFID
	5987178.001	Print head 4.3/300 RFID
	5987179.001	Print head 4/300 RFID
	5987180.001	Print head 4/600 RFID
	5987808.001 5987809.001	Print head 6.3/200 RFID Print head 6.3/300 RFID

User languages

Language	Assembly instructions	Control panel	Windows driver	Service manual	cablabel S3
European Union					
Bulgarian		X	X		X
Danish	X	X	X		
German	X	X	X	X	X
Estonian		X	X		
Finnish	X	X	X		
French	X	X	X		X
Greek		X	X		
English	X	X	X	X	X
Italian	X	X	X		X
Croatian		X	X		
Latvian		X	X		
Lithuanian		X	X		
Dutch	X	X	X		
Polish	X	X	X		X
Portuguese	X	X	X		
Romanian	X	X	X		
Swedish	X	X	X		
Slovak		X	X		
Slovenian	X	X	X		
Spanish	X	X	X		X
Czech	X	X	X		X
Hungarian	X	X	X		
Europe (Non-EU)					
Macedonian		X	X		
Norwegian		X	X		
Russian	X	X	X		X
Serbian		X	X		
Turkish		X	X		
Asia					
Chinese (simplified)	X	X	X		X
Chinese (traditional)	X	X	X		X
Japanese		X	X		
Korean	X	X	X		X
Thai		x	X		
Middle East					
Arabian		X			
Persian		X			

HERMES Q delivery program













Applicators L

Pos.	Part no.	Designation	Part no.	Transfer modules
4.1	 5987532	Swing applicator HQ 3214L-40	xxxxxxx xxxxxxx xxxxxxx xxxxxxx	Tamp-on pad 3214L-11 F W x H Tamp-on pad, providing a damping layer 3214L-12 F W x H Tamp-on pad, providing a label stop 3214L-61 F W x H Blow-on pad 3214L-2100 W x H
4.2	 5987549 5987550 5987551 5989352	Stroke applicator HQ 4114L-200 Stroke applicator HQ 4114L-300 Stroke applicator HQ 4114L-400 Stroke applicator HQ 4114L-600	xxxxxxx xxxxxxx xxxxxxx xxxxxxx	Tamp-on pad 4114L-11 F W x H Tamp-on pad, providing a damping layer 4114L-12 F W x H Tamp-on pad, providing a label stop 4114L-61 F W x H Blow-on pad 4114L-2100 W x H Form pad 4114L-8800 W x H
		5987802 5987803 5987804	Stroke applicator HQ 4116L-200 Stroke applicator HQ 4116L-300 Stroke applicator HQ 4116L-400	xxxxxxx xxxxxxx xxxxxxx xxxxxxx
4.3	 5987557 5987558 5987559	Stroke turn applicator HQ 4214L-200 Stroke turn applicator HQ 4214L-300 Stroke turn applicator HQ 4214L-400	xxxxxxx xxxxxxx xxxxxxx xxxxxxx	Tamp-on pad 4214L-11 F W x H Tamp-on pad, providing a damping layer 4214L-12 F W x H Tamp-on pad, providing a label stop 4214L-61 F W x H Blow-on pad 4214L-2100 W x H
4.4	 5987573 5987574 5987575	Stroke applicator HQ 4414L-200 Stroke applicator HQ 4414L-300 Stroke applicator HQ 4414L-400	xxxxxxx xxxxxxx xxxxxxx	Tamp-on pad 4414L-11 F W x H Tamp-on pad, providing a damping layer 4414L-12 F W x H Tamp-on pad, providing a label stop 4414L-61 F W x H
4.5	 5987724 5987726 5987728	Swing stroke applicator HQ 4514L-200 Swing stroke applicator HQ 4514L-300 Swing stroke applicator HQ 4514L-400	xxxxxxx	Blow-on pad 4514L-2100 W x H
4.6	 5987548	Flag applicator HQ 4712L-300	xxxxxxx	Form pad W x H
4.7	 5987520 5987521 5987522 5989343	Front side applicator HQ 3014L-200 Front side applicator HQ 3014L-300 Front side applicator HQ 3014L-400 Front side applicator HQ 3014L-600	xxxxxxx xxxxxxx xxxxxxx xxxxxxx	Tamp-on pad 3014L-1100 W x H Tamp-on pad, spring-mounted 3014L-3100 W x H Blow-on pad 3014L-2100 W x H
		5987523 5987524 5987525 5989346	Front side applicator HQ 3016L-200 Front side applicator HQ 3016L-300 Front side applicator HQ 3016L-400 Front side applicator HQ 3016L-600	xxxxxxx xxxxxxx xxxxxxx xxxxxxx
4.8	 5987534 5987535 5987536 5987537	Stroke applicator HQ 4014L-200 Stroke applicator HQ 4014L-300 Stroke applicator HQ 4014L-400 Stroke applicator HQ 4014L-600	5966147 5966148 5966149 5966150	Universal pad 4014L-1100 75 x 60 Universal pad 4014L-1100 90 x 90 Universal pad, spring-mounted 4014L-3100 116 x 102 Universal pad, spring-mounted 4014L-3100 116 x 152
		5987541 5987542 5987543 5989344	Stroke applicator HQ 4016L-200 Stroke applicator HQ 4016L-300 Stroke applicator HQ 4016L-400 Stroke applicator HQ 4016L-600	xxxxxxx xxxxxxx xxxxxxx xxxxxxx
4.9	 5989285 5989286 5989287 5989288	Stroke applicator HQ 4024L-200 Stroke applicator HQ 4024L-300 Stroke applicator HQ 4024L-400 Stroke applicator HQ 4024L-600	5989301 5989302 5989303	Vacuum pad 4024-3000 105 x 100 Vacuum pad 4024-3000 105 x 150 Vacuum pad 4024-3000 105 x 200
		5987736 5987738 5987740	Stroke blow applicator HQ 4614L-200 Stroke blow applicator HQ 4614L-300 Stroke blow applicator HQ 4614L-400	xxxxxxx
4.11	 6010890 5966144 5966146	Demand module HQ 5112L Demand module HQ 5114L Demand module HQ 5116L		
4.12	 5972870 5987552 5989291 5989292	Vacuum belt applicator HQ 5314L-2 Vacuum belt applicator HQ 5314L-3 Vacuum belt applicator HQ 5314L-4 Vacuum belt applicator HQ 5316L-2		
		5987710 5989293	Vacuum belt applicator HQ 5316L-3 Vacuum belt applicator HQ 5316L-4	
4.13	 5987714 5989294 5987718 5987720	Vacuum belt applicator HQ 5414L-3 Vacuum belt applicator HQ 5414L-4 Vacuum belt applicator HQ 5416L-3 Vacuum belt applicator HQ 5416L-4		
4.14	 6011850	Demand table HQ 5714L-100		
4.15	 5987564	Air jet box 5 templates are included HQ 6114L	5984709.001	Template 5 items are included in a pack unit 6114 L/R

xxxxxxx - customer-specific part no. subsequent to request



HERMES Q delivery program

Applicators R



Pos.		Part no.	Designation		Part no.	Transfer modules
4.1		5987533	Swing applicator	HQ3214R-40	xxxxxxx xxxxxxx xxxxxxx xxxxxxx	Tamp-on pad 3214L-11 F W x H Tamp-on pad, providing a damping layer 3214L-12 F W x H Tamp-on pad, providing a label stop 3214L-61 F W x H Blow-on pad 3214L-2100 W x H
4.2		5987553	Stroke applicator	HQ 4114R-200	xxxxxxx	Tamp-on pad 4114L-11 F W x H
		5987554	Stroke applicator	HQ 4114R-300	xxxxxxx	Tamp-on pad, providing a damping layer 4114L-12 F W x H
		5987555	Stroke applicator	HQ 4114R-400	xxxxxxx	Tamp-on pad, providing a label stop 4114L-61 F W x H
		5989353	Stroke applicator	HQ 4114R-600	xxxxxxx xxxxxxx	Blow-on pad 4114L-2100 W x H Form pad 4114L-8800 W x H
		5987812	Stroke applicator	HQ 4116R-200	xxxxxxx	Tamp-on pad 4116L-11 F W x H
		5987813	Stroke applicator	HQ 4116R-300	xxxxxxx	Tamp-on pad, providing a damping layer 4116L-12 F W x H
		5987814	Stroke applicator	HQ 4116R-400	xxxxxxx xxxxxxx	Tamp-on pad, providing a label stop 4116L-61 F W x H Form pad 4116L-8800 W x H
4.3		5987561	Stroke turn applicator	HQ 4214R-200	xxxxxxx	Tamp-on pad 4214L-11 F W x H
		5987562	Stroke turn applicator	HQ 4214R-300	xxxxxxx	Tamp-on pad, providing a damping layer 4214L-12 F W x H
		5987563	Stroke turn applicator	HQ 4214R-400	xxxxxxx xxxxxxx	Tamp-on pad, providing a label stop 4214L-61 F W x H Blow-on pad 4214L-2100 W x H
4.4		5987577	Stroke applicator	HQ 4414R-200	xxxxxxx	Tamp-on pad 4414L-11 F W x H
		5987578	Stroke applicator	HQ 4414R-300	xxxxxxx	Tamp-on pad, providing a damping layer 4414L-12 F W x H
		5987579	Stroke applicator	HQ 4414R-400	xxxxxxx	Tamp-on pad, providing a label stop 4414L-61 F W x H
4.5		5987730 5987732 5987734	Swing stroke applicator Swing stroke applicator Swing stroke applicator	HQ 4514R-200 HQ 4514R-300 HQ 4514R-400	xxxxxxx	Blow-on pad 4514L-2100 W x H
4.7		5987526	Front side applicator	HQ 3014R-200	xxxxxxx	Tamp-on pad 3014L-1100 W x H
		5987527	Front side applicator	HQ 3014R-300	xxxxxxx	Tamp-on pad, spring-mounted 3014L-3100 W x H
		5987528	Front side applicator	HQ 3014R-400	xxxxxxx	Blow-on pad 3014L-2100 W x H
		5989354	Front side applicator	HQ 3014R-600		
		5987529	Front side applicator	HQ 3016R-200		
		5987530	Front side applicator	HQ 3016R-300	xxxxxxx	Tamp-on pad 3016L-1100 W x H
4.8		5987531	Front side applicator	HQ 3016R-400	xxxxxxx	Tamp-on pad, spring-mounted 3016L-3100 W x H
		5989355	Front side applicator	HQ 3016R-600		
		5987538	Stroke applicator	HQ 4014R-200	5966140	Universal pad 4014L-1100 75 x 60
		5987539	Stroke applicator	HQ 4014R-300	5966141	Universal pad 4014L-1100 90 x 90
		5987540	Stroke applicator	HQ 4014R-400	5966142	Universal pad, spring-mounted 4014L-3100 116 x 102
		5989363	Stroke applicator	HQ 4014R-600	5966143	Universal pad, spring-mounted 4014L-3100 116 x 152
4.8					xxxxxxx	Tamp-on pad 4014L-11 F W x H
					xxxxxxx	Blow-on pad 4014L-2100 W x H
					xxxxxxx	Tamp-on pad, spring-mounted 4014L-3100 W x H
					xxxxxxx	Roll-on pad 4014L-4100 W x H
					xxxxxxx	Corner-wrap pad 4014L-5100 W x H / H
		5987545	Stroke applicator	HQ 4016R-200	xxxxxxx	Tamp-on pad 4016R-11 F W x H
5987546	Stroke applicator	HQ 4016R-300	xxxxxxx	Tamp-on pad, spring-mounted 4016R-3100 W x H		
5987547	Stroke applicator	HQ 4016R-400	xxxxxxx	Roll-on pad 4016R-4100 W x H		
5989356	Stroke applicator	HQ 4016R-600	xxxxxxx	Roll-on pad 4016R-4100 W x H		
4.9		5989295	Stroke applicator	HQ 4024R-200	5989301	Vacuum pad 4024-3000 105 x 100
		5989296	Stroke applicator	HQ 4024R-300	5989302	Vacuum pad 4024-3000 105 x 150
		5989297	Stroke applicator	HQ 4024R-400	5989303	Vacuum pad 4024-3000 105 x 200
		5989298	Stroke applicator	HQ 4024R-600		
4.10		5987742	Stroke blow applicator	HQ 4614R-200	xxxxxxx	Blow-on pad 4614L-2100 W x H
		5987744	Stroke blow applicator	HQ 4614R-300		
		5987746	Stroke blow applicator	HQ 4614R-400		
4.11		6010910	Demand module	HQ 5112R		
		5966145	Demand module	HQ 5114R		
		5966152	Demand module	HQ 5116R		
4.12		5987708	Vacuum belt applicator	HQ 5314R-2		
		5987556	Vacuum belt applicator	HQ 5314R-3		
		5989357	Vacuum belt applicator	HQ 5314R-4		
		5989358	Vacuum belt applicator	HQ 5316R-2		
		5987712	Vacuum belt applicator	HQ 5316R-3		
4.13		5989359	Vacuum belt applicator	HQ 5316R-4		
		5987716	Vacuum belt applicator	HQ 5414R-3		
		5989360	Vacuum belt applicator	HQ 5414R-4		
		5987722	Vacuum belt applicator	HQ 5416R-3		
		5989361	Vacuum belt applicator	HQ 5416R-4		
4.15		5987565	Air jet box 5 templates are included	HQ 6114R	5984709.001	Template 5 items are included in a pack unit 6114 L/R

xxxxxxx - customer-specific part no. subsequent to request

Accessories provided for applicators

Pos.		Part no.	Designation
5.13		5964277.001 5964095.001 5964614.001	Blow tube 2" Blow tube 4" Blow tube 6"
5.14		6010880 6010881	Unit L to regulate compressed air Unit R to regulate compressed air
5.16		5984805 5984795	Unit L to regulate compressed air, providing a shut-off valve Unit R to regulate compressed air, providing a shut-off valve

Options provided for applicators

Pos.		Part no.	Designation
5.17		596xxxx.212	Pressure-reducing valve
		xxxx - applicator part no.	
5.18		596xxxx.220	Pressure-reduced applicator suitable for HQ 4014, HQ 4114, HQ 4414, HQ 4214 / 300 stroke
		xxxx - applicator part no.	

Tools for assembly

Pos.		Part no.	Designation
6.1		5965940	Adapter plate
6.2		5958365 5965929 5971721 5987701 5987702 5987703	Profile 40 Profile 80 Profile 120 Profile 160 Profile 200 Profile 300
6.3		5961203	Base plate 500 x 255 mm
6.4		5989277	Base plate with XY Stop and product sensor
6.5		5955685	Bracket
6.6		8914443	Clamped joint designed for a 50 x 50 mm profile
6.7		8914444	Flanged joint designed for a 50 x 50 mm profile

Floor stands

Pos.		Part no.	Designation
6.8		5970113	Floor stand 1601
6.9		5970112	Floor stand 1602
6.10		5972515	Floor stand 1201

Overview of cab products

Label printers
MACH1, MACH2



Label printers
EOS 2



Label printers
EOS 5



Label printers
MACH 4S



Label printers
SQUIX 2



Label printers
SQUIX 4



Label printers
SQUIX 6.3



Label printers
SQUIX 8.3



Label printers
XD Q double-sided



Label printers
XC Q two-colored



Print and apply systems
HERMES Q



Print and apply systems
Hermes C two-colored

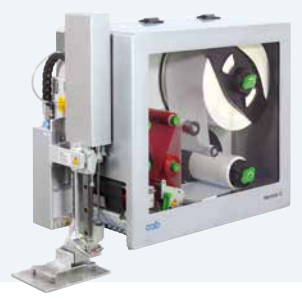

Tube labeling systems
AXON 1



Print modules
PX Q



Labels and ribbons



Label software
cablabel S3



Label dispensers
HS, VS



Labeling heads
IXOR



Marking lasers
XENO 4



Laser marking systems



Germany

cab Produkttechnik GmbH & Co KG

Karlsruhe

Phone +49 721 6626 0

www.cab.de

France

cab Technologies S.à.r.l.

Niedermodern

Phone +33 388 722501

www.cab.de/fr

USA

cab Technology, Inc.

Chelmsford, MA

Phone +1 978 250 8321

www.cab.de/us

Mexico

cab Technology, Inc.

Juárez

Phone +52 656 682 4301

www.cab.de/es

Taiwan

cab Technology Co., Ltd.

Taipei

Phone +886 (02) 8227 3966

www.cab.de/tw

China

cab (Shanghai) Trading Co., Ltd.

Shanghai

Phone +86 (021) 6236 3161

www.cab.de/cn

Singapore

cab Singapore Pte. Ltd.

Singapore

Phone +65 6931 9099

www.cab.de/en

South Africa

cab Technology (Pty) Ltd.

Randburg

Phone +27 11 886 3580

www.cab.de/za

cab // 820 distribution and service partners in more than **80** countries